

A New Algorithm for Proving Global Asymptotic Stability of Rational Difference Equations

Emilie Hogan and Doron Zeilberger

Department of Mathematics

Rutgers, The State University of New Jersey

Piscataway, NJ 08854-8019

{eahogan, zeilberg}@math.rutgers.edu

June 22, 2011

Abstract

Global asymptotic stability of rational difference equations is an area of research that has been well studied. In contrast to the many current methods for proving global asymptotic stability, we propose an algorithmic approach. The algorithm we summarize here employs the idea of contractions. Given a particular rational difference equation, defined by a function $Q : \mathbb{R}^{k+1} \rightarrow \mathbb{R}^{k+1}$, we attempt to find a K value for which Q^K shrinks distances to the difference equation's equilibrium point. We state some general results that our algorithm has been able to prove, and also mention the implementation of our algorithm using Maple.

1 Introduction

In this paper we will introduce an algorithmic approach to proving *global asymptotic stability (GAS)* of equilibrium points of rational difference equations. The field of rational difference equations has applications to many other fields including biology, economics, and dynamical systems. In application areas, one often studies time-evolving sequences produced by recurrences with the goal of discovering end behavior of the sequence, given some initial conditions. There are many types of end behavior that one may be interested in. We will be concerned only with global asymptotic stability. Essentially, given a fixed rational difference equation, when the sequence that it produces converges for *any* reasonable initial conditions, we say that it is GAS. In Section 1.1, we will state the precise definition for GAS, as well as introduce all of the other definitions necessary to study stability of difference equations. We will also state a theorem, originally proved in [8], which will be the basis of our algorithm. The main algorithm is presented in Sections 2 and 3. In the algorithm we first reduce the problem of GAS to the problem of proving that a particular polynomial is positive. Then, we prove that a multivariate polynomial is positive (when all of its variables are taken to be positive) using our new algorithm. Next, Section 4 contains a proof-of-concept that our algorithm is indeed applicable to prove GAS. In Section 5 we state a few of the results that our algorithm can prove. In addition, in Section 6, we mention the most useful commands in the Maple package that accompanies this paper.

1.1 Definitions

Following the various works of Ladas, et. al. [2, 7, 9], we begin by stating a few standard definitions needed to study rational difference equations and stability.

Definition 1.1. A *rational difference equation* (of order $k + 1$) is an equation of the form

$$x_{n+1} = R(x_n, x_{n-1}, \dots, x_{n-k}) \tag{1}$$

where the function $R(u_0, u_1, \dots, u_k)$ is a rational function which maps I^{k+1} to I , for some interval $I \subseteq \mathbb{R}$. Typically, we will take I to be $[0, \infty)$ or $(0, \infty)$.

Given a function R we say that a *solution* of (1) is a sequence $\{x_n\}_{n=-k}^{\infty}$ which satisfies (1). One can also think of a solution, $\{x_n\}_{n=-k}^{\infty}$, as being associated to the specific initial conditions $\{x_{-k}, \dots, x_0\}$ created by repeatedly applying R . If a solution is constant, $x_n = \bar{x}$, for all $n \geq -k$ then we say that the solution is an *equilibrium solution*, and \bar{x} is called an *equilibrium point*, or simply an *equilibrium* of F . In practice, we find the equilibria by solving the equation $\bar{x} = R(\bar{x}, \dots, \bar{x})$, and taking the solutions which lie in the interval I .

The main topic to be investigated in this paper is end behavior, specifically *stability*, of a solution of a given difference equation. There are various notions of stability that will now be defined.

Definition 1.2. An equilibrium point, \bar{x} , of (1) is said to be

1. *locally stable* if for every $\varepsilon > 0$ there exists $\delta > 0$ such that if $\{x_n\}_{n=-k}^{\infty}$ is a solution to (1) with the property that

$$|x_{-k} - \bar{x}| + |x_{-k+1} - \bar{x}| + \dots + |x_0 - \bar{x}| < \delta$$

then $|x_n - \bar{x}| < \varepsilon$ for all $n \geq 0$.

2. *locally asymptotically stable (LAS)* if \bar{x} is locally stable, and if there exists a $\gamma > 0$ such that if $\{x_n\}_{n=-k}^{\infty}$ is a solution to (1) with the property that

$$|x_{-k} - \bar{x}| + |x_{-k+1} - \bar{x}| + \dots + |x_0 - \bar{x}| < \gamma$$

then

$$\lim_{n \rightarrow \infty} x_n = \bar{x}$$

3. a *global attractor* if for every solution, $\{x_n\}_{n=-k}^{\infty}$, of (1) we have

$$\lim_{n \rightarrow \infty} x_n = \bar{x}$$

4. *globally asymptotically stable (GAS)* if \bar{x} is a global attractor, and \bar{x} is locally stable.
5. *unstable* if \bar{x} is not locally stable.

Our goal in this paper is to present an algorithm to prove GAS. Since GAS implies LAS, the first step must be to prove LAS (since, if a difference equation is not LAS it can't be GAS). The *linearized stability theorem*, which provides easily verifiable criteria for local asymptotic stability, can be found in many books and papers [2, 3, 4, 9, 11]. Because it is not central to our algorithm, we will omit the theorem and notation needed to state it.

In contrast to local asymptotic stability which is relatively easy to verify using the linearized stability theorem, global asymptotic stability has no similarly general necessary and sufficient conditions. There are a handful of theorems, providing sufficient conditions, that have been used to verify the global asymptotic stability of many specific difference equations. However, given a difference equation defined by the function R , it is not always obvious which theorem to apply. For a discussion of many of these theorems see [2].

Our algorithm will only rely on the following theorem which is first presented in a paper by Kruse and Neseemann [8]. It will be stated in a slightly different manner than it appears in their paper, using the notation we have established in this paper. First, it will be necessary to consider the difference equation associated to a function R in vector form. Let $Q : I^{k+1} \rightarrow I^{k+1}$ be defined from R as

$$Q(\mathcal{X}_n) = Q \left(\begin{bmatrix} x_n \\ x_{n-1} \\ \vdots \\ x_{n-k} \end{bmatrix} \right) = \begin{bmatrix} R(x_n, \dots, x_{n-k}) \\ x_n \\ \vdots \\ x_{n-k+1} \end{bmatrix} = \mathcal{X}_{n+1}. \quad (2)$$

Note that this transformation from R to Q essentially creates an order 1 mapping out of an order $k+1$ mapping. In addition, Q is now a map that can be composed with itself, so

$$\mathcal{X}_n = Q^n(\mathcal{X}_0)$$

where $\mathcal{X}_0 = \langle x_0, \dots, x_{-k} \rangle$ is the vector of initial conditions. Now we can state the theorem.

Theorem 1.1 (Kruse, Neesemann 1999). Let $\|\cdot\|$ denote the Euclidean norm (i.e., $\|(a, b)\| = \sqrt{a^2 + b^2}$). Let \mathbb{S} denote either $[0, \infty)$ or $(0, \infty)$ (the function Q will necessitate which). Let $Q : \mathbb{S}^{k+1} \rightarrow \mathbb{S}^{k+1}$ be a continuous mapping of the form (2) with a unique fixed point $\bar{\mathcal{X}} \in \mathbb{S}^{k+1}$. Suppose for the discrete dynamic system

$$\mathcal{X}_{n+1} = Q(\mathcal{X}_n), \quad n = 0, 1, 2, \dots \quad (3)$$

there exists an integer $K \geq 1$ such that the K^{th} iterate of Q satisfies

$$\|Q^K(\mathcal{X}) - \bar{\mathcal{X}}\| < \|\mathcal{X} - \bar{\mathcal{X}}\| \quad \text{for all } \mathcal{X} \in \mathbb{S}^{k+1}, \mathcal{X} \neq \bar{\mathcal{X}}. \quad (4)$$

Then $\bar{\mathcal{X}}$ is GAS with respect to the norm $\|\cdot\|$.

First, notice that this integer K tells us which power of Q is a contraction with respect to $\bar{\mathcal{X}}$, i.e., Q^K shrinks distances to $\bar{\mathcal{X}}$. This gives an intuitive reason for $\|Q^K(\mathcal{X}) - \bar{\mathcal{X}}\| < \|\mathcal{X} - \bar{\mathcal{X}}\|$ to imply global asymptotic stability. The proof of this theorem can be found in [8].

Notice that the various definitions of stability, as they were stated in Definition 1.2, do not quite apply here because our unique fixed point (or equilibrium) is a vector rather than a scalar. However, Definition 1.2, can be easily translated to the vector case. The recurrence is (3), the equilibrium is a vector solution to the equation $Q(\bar{\mathcal{X}}) = \bar{\mathcal{X}}$, and the order of the recurrence, $k+1$, is 1 (so $k=0$). Other than these minor changes, a word for word translation of Definition 1.2 is what we mean by $\bar{\mathcal{X}}$ being GAS in Theorem 1.1.

Next we will see how we utilized this theorem to create a global asymptotic stability proof algorithm.

2 From Global Asymptotic Stability to Polynomial Positivity

In this section we will see how to reduce the question of global asymptotic stability of a rational difference equation to a question about an associated polynomial being positive. Throughout this section assume that we have fixed a rational difference equation,

$$x_{n+1} = R(x_n, \dots, x_{n-k}), \quad (5)$$

of order $k+1$, with a unique equilibrium \bar{x} . Also assume that R is a rational function with positive coefficients, so $R : [0, \infty)^{k+1} \rightarrow [0, \infty)$, and \bar{x} is non-negative (if there is no constant term in the denominator of R we cannot allow 0 to be in the domain, so $R : (0, \infty)^{k+1} \rightarrow (0, \infty)$, and \bar{x} must be strictly positive). In order to apply Theorem 1.1 we must think of (5) and its equilibrium in their vector forms. For example, if $x_{n+1} = \frac{4+x_n}{1+x_{n-1}}$ then

$$Q \left(\begin{bmatrix} x_n \\ x_{n-1} \end{bmatrix} \right) = \begin{bmatrix} \frac{4+x_n}{1+x_{n-1}} \\ x_n \end{bmatrix},$$

and $\bar{\mathcal{X}} = \langle 2, 2 \rangle$. In this case $k=1$, so $R : [0, \infty)^2 \rightarrow [0, \infty)$, and $Q : [0, \infty)^2 \rightarrow [0, \infty)^2$.

The goal will be to find a positive integer, K , which satisfies (4). Motivated by this goal, we will construct the following polynomial, given specific Q , $\bar{\mathcal{X}}$, and K (assume we have conjectured some value for K):

$$P_{Q, \bar{\mathcal{X}}, K}(\mathcal{X}) = \text{numerator} \left(\|\mathcal{X} - \bar{\mathcal{X}}\|^2 - \|Q^K(\mathcal{X}) - \bar{\mathcal{X}}\|^2 \right). \quad (6)$$

Consider the implication of $P_{Q, \bar{\mathcal{X}}, K} > 0$ for $\mathcal{X} \geq 0$ (or > 0 , both componentwise), and $\mathcal{X} \neq \bar{\mathcal{X}}$.

$$\begin{aligned} 0 &< \text{numerator} \left(\|\mathcal{X} - \bar{\mathcal{X}}\|^2 - \|Q^K(\mathcal{X}) - \bar{\mathcal{X}}\|^2 \right) \\ \iff 0 &< \|\mathcal{X} - \bar{\mathcal{X}}\|^2 - \|Q^K(\mathcal{X}) - \bar{\mathcal{X}}\|^2 \\ \iff \|Q^K(\mathcal{X}) - \bar{\mathcal{X}}\|^2 &< \|\mathcal{X} - \bar{\mathcal{X}}\|^2 \\ \iff \|Q^K(\mathcal{X}) - \bar{\mathcal{X}}\| &< \|\mathcal{X} - \bar{\mathcal{X}}\|. \end{aligned} \quad (7)$$

Of course, the first implication, undoing the numerator from line 1 to line 2, in general will not preserve an inequality since the denominator may be negative. However, because we are squaring the Euclidean norm, the common denominator is always a product of sums of squares. Taking the numerator is then equivalent to multiplying both sides by the denominator, a positive quantity, which will not change the direction of the inequality. Notice that the final implicant, (7), is simply (4), so proving $P_{Q,\bar{x},K} > 0$ for some K implies that \bar{x} is GAS for the rational difference equation R . An algorithm for proving positivity will be shown in Section 3. Also note that whenever the function Q and equilibrium are clear from context, they will be omitted from the subscript of P .

For a given Q and \bar{x} we know that showing positivity of an associated polynomial implies GAS of \bar{x} for R . We also know, given K , what that polynomial associated to Q and \bar{x} is. However, we still need to see how to conjecture a reasonable value for K , and then how to prove that the polynomial is indeed positive. We will see how to prove positivity in the next section. Now let's see how to conjecture a reasonable K value given R and \bar{x} using a brute force method. Start with $K = 1$ and apply the following algorithm:

1. Create the polynomial $P_{Q,\bar{x},K}(\mathcal{X})$
2. Apply a minimization technique to the polynomial $P_{Q,\bar{x},K}(\mathcal{X})$ (e.g., simulated annealing, gradient descent, Metropolis-Hastings algorithm, etc.) many times to find approximate local minima of $P_{Q,\bar{x},K}$.
3. (a) If all approximate local minima are positive then conjecture that this K works.
(b) If there is a negative minima then increment K by 1 and go back to step 1.

For ease of computation, and since this is only to conjecture a K , we apply the minimization technique in step 2 to a discrete set of points. We will restrict to a fine mesh with large upper bound. For example, the cartesian product $\times_{i=1}^{k+1} \{\varepsilon, 2\varepsilon, \dots, N\varepsilon\}$, for some large value of N and small value of ε . Then every point in the mesh is a vector of the form $\langle i_1\varepsilon, i_2\varepsilon, \dots, i_{k+1}\varepsilon \rangle$, where $1 \leq i_j \leq N$.

Note that this is not the only possible algorithm for conjecturing a value for K . However, the main result in this paper is a positivity algorithm, so we will not consider other possible algorithms. One could, in theory, replace step 2 with the following, "Apply the polynomial positivity algorithm found in Section 3". Then step 3 would become, "If the algorithm in step 2 fails, increase K by 1 and go back to step 1, otherwise return K ". Using this positivity algorithm, once a K value is found, it is also proved to be correct. However, using positivity in step 2 is sometimes not feasible since it often takes more computer memory than the conjecturing algorithm.

3 An Algorithm to Prove Positivity of a Multivariate Polynomial

So far, our algorithm to prove global asymptotic stability of a particular rational difference equation has reduced the problem to proving that an associated polynomial is positive. Now the question becomes, how does one prove positivity? In general one can show polynomial positivity using calculus, or using cylindrical algebraic decomposition [1]. However, both of these methods do not work particularly well when the polynomial has very high degree. This is typically the case for the polynomials produced in Section 2, so we must use a different algorithm. We propose a new algorithm which was inspired by the following definition and theorem found in [6].

Definition 3.1. The polynomial $P \in \mathbb{R}[x_1, \dots, x_n]$ is

- *positive* (resp. *non-negative*) from μ iff $\forall x_1 \geq \mu, \dots, x_n \geq \mu, P(x_1, \dots, x_n) > 0$ (resp. $P(x_1, \dots, x_n) \geq 0$).
- *absolutely positive* (resp. *absolutely non-negative*) from μ iff P is positive (resp. non-negative) from μ , and every partial derivative (of any order), P^* , of P is non-negative from μ , i.e., $\forall x_1 \geq \mu, x_2 \geq \mu, \dots, x_n \geq \mu, P^*(x_1, \dots, x_n) \geq 0$.

In addition, we will denote by $\sigma_{\mu_1, \dots, \mu_n}(P)$ the polynomial obtained from P by translating in dimension i by μ_i in the negative direction. In other words, replace x_i by $x_i + \mu_i$ in P for all i . If $\mu_i = \mu$ for all i then we simply write $\sigma_\mu(P)$. Also from [6], a theorem that gives a necessary and sufficient condition for absolute positivity (and absolute non-negativity) is reproduced here.

Theorem 3.1 (Hong, Jakuš 1998). *Let P be a non-zero polynomial. Then P is absolutely positive (resp. absolutely non-negative) from μ iff every coefficient in $\sigma_\mu(P)$ is positive, and the constant term is nonzero (resp. non-negative). In particular, if $\mu = 0$ then every coefficient in P is positive and the constant term is nonzero (resp. non-negative).*

Now, it is certainly too much to hope for the polynomials $P_{Q,\bar{x},K}$ to be *absolutely* positive from zero. Of course, to satisfy Theorem 1.1, it is only necessary that they be positive from zero (and possibly zero at a few points). Our algorithm will subdivide the positive *orthant* (the region in which all the variables are non-negative), denoted by \mathbb{R}_+^n where n is the number of variables in P , into regions in which P is positive on the boundary of the region, and essentially absolutely positive in some direction away from the boundary (i.e., there is a direction such that the directional derivative is positive).

Since the polynomials we construct while pursuing global asymptotic stability are typically very complicated (high degree in all variables, some negative coefficients), we cannot easily show that a directional derivative is positive. Instead, for each region $S \subset \mathbb{R}_+^n$ we will create a polynomial, $P_S(y)$ with the property that if $P_S(y) \geq 0$ for all $y \in \mathbb{R}_+^n$ then $P(x) \geq 0$ for all $x \in S$. We will first describe the algorithm in two dimensions, and later generalize to the n -dimensional case.

Let $P := P(x, y)$ be a polynomial in two variables ($n = 2$). In order to show that $P(x, y) \geq 0$ for $(x, y) \in \mathbb{R}_+^2$, we first cut the positive quadrant into 4 regions as shown in Figure 1, where \bar{x} is some positive number. In the case that $P = P_{Q,\bar{x},K}$ as in Section 2, \bar{x} will be the equilibrium point of the rational difference equation used to create P .

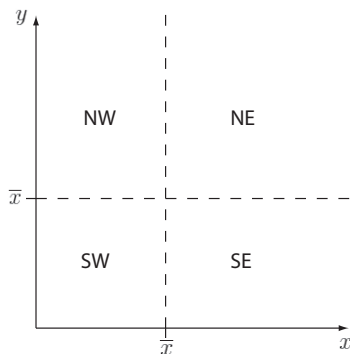

Figure 1: Cutting \mathbb{R}_+^2 into 4 regions

For each of these four regions we create a new polynomial from P by transforming the region into \mathbb{R}_+^2 , and making the corresponding variable substitutions. See Figures 2 - 4 for the region transformations (transforming SE is analogous to transforming NW by permuting the x and y axes). Based on these region transformations we see that the associated polynomials are given by

$$\begin{aligned}
 P_{NE}(x, y) &= \sigma_{\bar{x}}(P) = P(x + \bar{x}, y + \bar{x}), \\
 P_{SW}(x, y) &= \sigma_{\frac{1}{\bar{x}}} \left(P \left(\frac{1}{x}, \frac{1}{y} \right) x^{d_x} y^{d_y} \right) \\
 &= P \left(\frac{1}{x + \frac{1}{\bar{x}}}, \frac{1}{y + \frac{1}{\bar{x}}} \right) \left(x + \frac{1}{\bar{x}} \right)^{d_x} \left(y + \frac{1}{\bar{x}} \right)^{d_y}, \\
 P_{NW}(x, y) &= \sigma_{\frac{1}{\bar{x}}, \bar{x}} \left(P \left(\frac{1}{x}, y \right) x^{d_x} \right) = P \left(\frac{1}{x + \frac{1}{\bar{x}}}, y + \bar{x} \right) \left(x + \frac{1}{\bar{x}} \right)^{d_x}, \\
 P_{SE}(x, y) &= \sigma_{\bar{x}, \frac{1}{\bar{x}}} \left(P \left(x, \frac{1}{y} \right) y^{d_y} \right) = P \left(x + \bar{x}, \frac{1}{y + \frac{1}{\bar{x}}} \right) \left(y + \frac{1}{\bar{x}} \right)^{d_y}.
 \end{aligned} \tag{8}$$

The change of variables in P before applying σ , inverting the variables or not, is self explanatory based on the transformation of the associated region. However, we must also multiply by x^{d_x} and/or y^{d_y} (where d_z = the degree of z in P for $z = x, y$) as needed before applying the σ shift operator so that the resulting

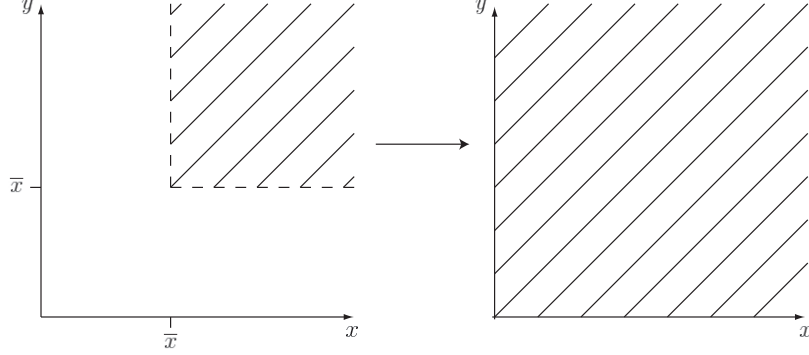

Figure 2: Transforming NE to \mathbb{R}_+^2

P_\square is still a polynomial. When talking generally about one of these polynomials, we will denote it by P_\square , where the \square can refer to an arbitrary region. Note that if $\bar{x} = 0$ we will only consider the *NE* region, thus avoiding translating by $\frac{1}{\bar{x}} = \frac{1}{0}$.

Before we continue the algorithm by giving criteria to test positivity of the polynomials in (8) we must see why proving positivity of all P_\square will be enough to prove positivity of $P(x, y)$ for all $(x, y) \in \mathbb{R}_+^2$.

Proposition 3.2. *Let $P(x, y)$ be a polynomial, $d_x = \deg_x(P)$, $d_y = \deg_y(P)$, and $\bar{x} > 0$. Consider the polynomials $P_{NE}, P_{SW}, P_{NW}, P_{SE}$ as defined in (8). If these four polynomials are all non-negative from 0 then $P(x, y)$ is non-negative from 0.*

Proof. For each of the four polynomials we will see that positivity for $(x, y) \in \mathbb{R}_+^2$ implies positivity of $P(x, y)$ in the corresponding region.

If $P_{NE}(x, y) \geq 0$ for $(x, y) \in \mathbb{R}_+^2$: Then by definition of $P_{NE}(x, y)$ we have

$$P_{NE}(x, y) = P(x + \bar{x}, y + \bar{x}) \geq 0 \quad \text{for } x \geq 0, y \geq 0.$$

Let $x' := x + \bar{x}$ and $y' := y + \bar{x}$, then

$$P(x', y') \geq 0 \quad \text{for } x' = x + \bar{x} \geq \bar{x}, \text{ and } y' = y + \bar{x} \geq \bar{x}.$$

This says precisely that $P(x, y) \geq 0$ in the region *NE*.

If $P_{SW}(x, y) \geq 0$ for $(x, y) \in \mathbb{R}_+^2$: Again, by definition of $P_{SW}(x, y)$

$$P_{SW}(x, y) = P\left(\frac{1}{x + \frac{1}{\bar{x}}}, \frac{1}{y + \frac{1}{\bar{x}}}\right) \left(x + \frac{1}{\bar{x}}\right)^{d_x} \left(y + \frac{1}{\bar{x}}\right)^{d_y} \geq 0$$

for $x \geq 0, y \geq 0$.

Following the previous case we first substitute $x' := x + \frac{1}{\bar{x}}$ and $y' := y + \frac{1}{\bar{x}}$ to get

$$P\left(\frac{1}{x'}, \frac{1}{y'}\right) (x')^{d_x} (y')^{d_y} \geq 0 \quad \text{for } x' = x + \frac{1}{\bar{x}} \geq \frac{1}{\bar{x}}, \text{ and } y' = y + \frac{1}{\bar{x}} \geq \frac{1}{\bar{x}}.$$

Since we are only interested in the region for which x' and y' are both strictly positive we may cancel the $(x')^{d_x} (y')^{d_y}$ without reversing the inequality. We also make a second substitution letting $x'' := \frac{1}{x'}$ and $y'' := \frac{1}{y'}$. Now we see that

$$P(x'', y'') \geq 0 \quad \text{for } 0 < x'' = \frac{1}{x'} \leq \bar{x}, \text{ and } 0 < y'' = \frac{1}{y'} \leq \bar{x}$$

which is simply $P(x, y) \geq 0$ in the region *SW*.

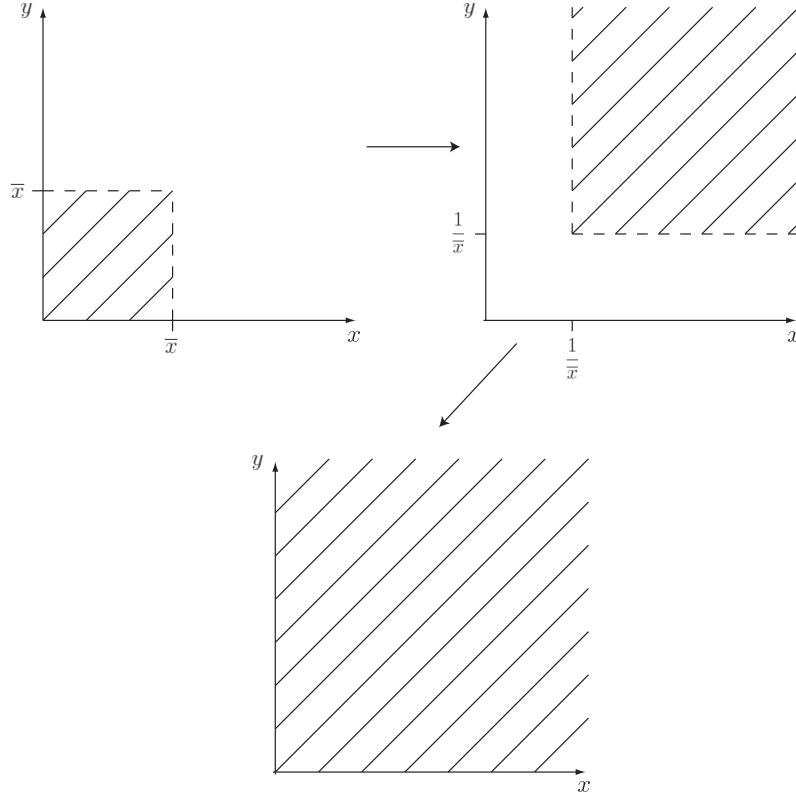

Figure 3: Transforming SW to \mathbb{R}_+^2

If $P_{NW}(x, y) \geq 0$ for $(x, y) \in \mathbb{R}_+^2$: From the definition in (8) this means

$$P_{NW}(x, y) = P\left(\frac{1}{x + \frac{1}{\bar{x}}}, y + \bar{x}\right) \left(x + \frac{1}{\bar{x}}\right)^{d_x} \geq 0 \quad \text{for } x \geq 0, y \geq 0.$$

As in the *SW* case, we will make two substitutions. The first being $x' := x + \frac{1}{\bar{x}}$ and $y' := y + \bar{x}$. This gives us

$$P\left(\frac{1}{x'}, y'\right) (x')^{d_x} \geq 0 \quad \text{for } x' = x + \frac{1}{\bar{x}} \geq \frac{1}{\bar{x}}, \text{ and } y' = y + \bar{x} \geq \bar{x}.$$

Again, we may cancel the $(x')^{d_x}$ without reversing the inequality since x' is strictly positive in the region in question. Finally, we make our second substitution, $x'' := \frac{1}{x'}$ (there is no second substitution for y') which yields

$$P(x'', y') \geq 0 \quad \text{for } 0 < x'' = \frac{1}{x'} \leq \bar{x}, \text{ and } y' \geq \bar{x}.$$

Therefore, $P(x, y) \geq 0$ in the region *NW*.

If $P_{SE}(x, y) \geq 0$ for $(x, y) \in \mathbb{R}_+^2$: This case is analogous to the *NW* case by interchanging the roles of x and y .

In each of the four cases positivity of the polynomial corresponds to positivity of $P(x, y)$ in the corresponding region. \square

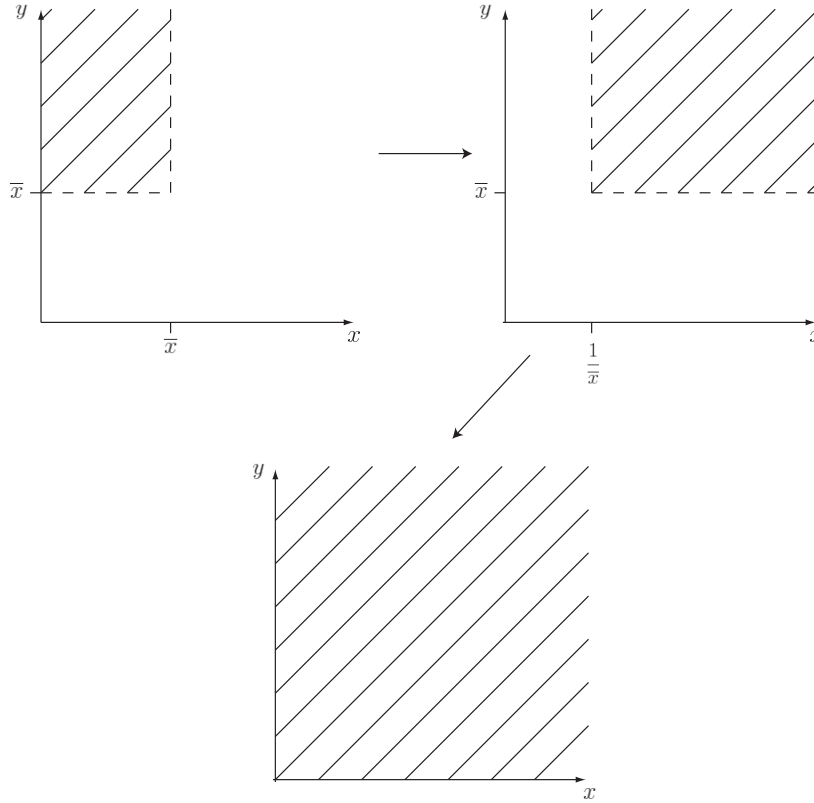

Figure 4: Transforming NW to \mathbb{R}_+^2

To prove positivity of each of the P_{\square} we will test two criteria, neither using anything more powerful than high school algebra.

PosCoeffs: From Theorem 3.1, if all coefficients, including the constant term, of P_{\square} are non-negative then $P_{\square}(x, y) \geq 0$ for $(x, y) \in \mathbb{R}_+^2$.

SubPoly: If the only negative coefficient in P_{\square} (including the constant term) is on the xy term then we check whether the binary quadratic form,

$$ax^2 + bxy + cy^2 \tag{9}$$

where a , b , and c are coefficients of their respective terms in P_{\square} , is positive definite (i.e., is positive for all $(x, y) \neq 0$) using its discriminant. The binary quadratic form discriminant of (9) is defined to be $d = 4ac - b^2$ [12]. If $a, d > 0$, then (9) is positive. Then, if this “sub-polynomial” of P_{\square} is positive, P_{\square} itself is positive (since the other coefficients are positive). Notice that this may not be the discriminant most are familiar with. A further discussion of why this is taken to be the discriminant can be found when the n -dimensional positivity algorithm is summarized later in this section.

We also have an easy way to test whether $P(x, y) < 0$ for some $(x, y) \in \mathbb{R}_+^2$ by checking the leading coefficient (the coefficient on the highest degree term) and constant term.

LCoeff: The leading coefficient must be positive, otherwise the polynomial eventually tends to negative infinity in some direction.

Const: Similarly, the constant term must be positive, otherwise the polynomial is negative in a neighborhood of the origin.

For each region \square , if P_{\square} passes one of **PosCoeffs** or **SubPoly** then, by Proposition 3.2, $P(x, y) \geq 0$ in the region \square . If P_{\square} fails one of **LCoeff** or **Const** then we output **false** immediately because we know that there are points in region \square for which $P(x, y)$ is negative. However, for some region \square , if P_{\square} has too many negative coefficients, its leading coefficient is positive, and its constant term is positive, then we must do more tests to establish positivity of P_{\square} on \mathbb{R}_+^2 .

We would like to subdivide our original region (NE, NW, SE, or SW) into finitely many pieces and try again. However, there isn't an obvious way to do this since, except for SW, the regions are infinite, and we have used our "obvious" cutpoint, \bar{x} . So instead, we will first map the infinite region into a finite rectangle with lower left corner at the origin (see figures 5 and 6) and create a new polynomial $P'_{\square}(x, y)$ from $P(x, y)$ for each now finite region. We will then subdivide this finite region in order to prove that $P'_{\square}(x, y) \geq 0$ on the region in which it is defined. These new polynomials will be defined in the following manner based on their corresponding region transformations.

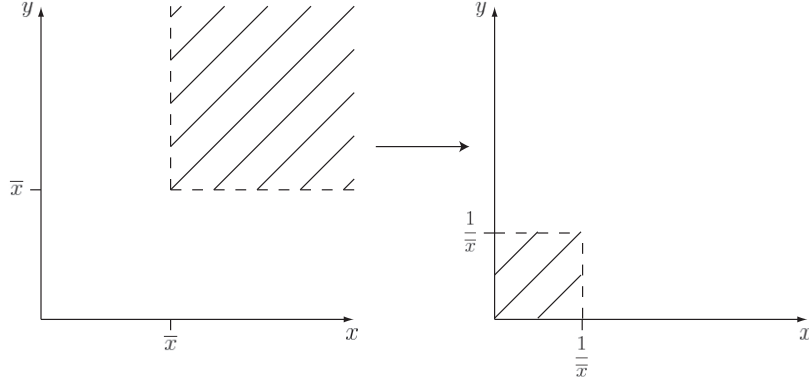

Figure 5: Transforming NE to finite rectangle

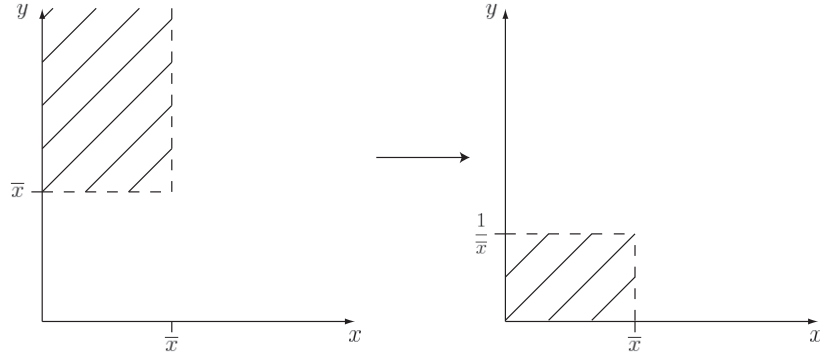

Figure 6: Transforming NW to finite rectangle (SE similar by interchanging axes)

$$\begin{aligned}
 P'_{NE}(x, y) &= P\left(\frac{1}{x}, \frac{1}{y}\right) x^{d_x} y^{d_y} && \text{restricted to } 0 < x, y \leq \frac{1}{\bar{x}} \\
 P'_{NW}(x, y) &= P\left(x, \frac{1}{y}\right) y^{d_y} && \text{restricted to } 0 \leq x \leq \bar{x}, 0 < y \leq \frac{1}{\bar{x}} \\
 P'_{SE}(x, y) &= P\left(\frac{1}{x}, y\right) x^{d_x} && \text{restricted to } 0 < x \leq \frac{1}{\bar{x}}, 0 \leq y \leq \bar{x} \\
 P'_{SW}(x, y) &= P(x, y) && \text{restricted to } 0 \leq x \leq \bar{x}, 0 < y \leq \frac{1}{\bar{x}}
 \end{aligned} \tag{10}$$

Along the lines of Proposition 3.2 we can guarantee positivity of $P(x, y)$ given positivity of the related polynomials (10).

Proposition 3.3. *Let $P(x, y)$ be a polynomial, $d_x = \deg_x(P)$, $d_y = \deg_y(P)$, and $\bar{x} > 0$. Consider the polynomials $P'_{NE}, P'_{SW}, P'_{NW}, P'_{SE}$ as defined in (10). If any one of these polynomials, generally denoted P'_\square , is positive on the region indicated in (10), then $P(x, y)$ is positive on the region \square . For example, if $P'_{NW}(x, y) \geq 0$ on $0 \leq x \leq \bar{x}$ and $0 < y \leq \frac{1}{\bar{x}}$, then $P(x, y) \geq 0$ on the region NW , and similarly for the other polynomials/regions.*

Proof. We will only see the proof for $P'_{NW}(x, y)$, the rest will follow in nearly the same manner. Assume that $P'_{NW}(x, y) \geq 0$ for $0 \leq x \leq \bar{x}$ and $0 < y \leq \frac{1}{\bar{x}}$. Then by definition of $P'_{NW}(x, y)$ we know that

$$P\left(x, \frac{1}{y}\right) y^{d_y} \geq 0 \quad \text{for } 0 \leq x \leq \bar{x}, 0 < y \leq \frac{1}{\bar{x}}.$$

Since y is strictly positive in the region in which $P'_{NW}(x, y)$ is defined, we can cancel y^{d_y} without reversing the inequality just as we did in the proof of Proposition 3.2. Now, let $y' := \frac{1}{y}$ to see that

$$P(x, y') \geq 0$$

for $0 \leq x \leq \bar{x}$ and $y' = \frac{1}{y} \geq \bar{x}$, which is precisely the region NW . The other regions will follow by doing substitutions $x' := \frac{1}{x}$ and $y' := \frac{1}{y}$ as necessary. Note that no work needs to be done for SW since $P'_{SW}(x, y) = P(x, y)$ and is defined in the region SW . \square

Next, we need to see how to prove that $P'_\square(x, y) \geq 0$ on the desired region. We will do this by subdividing the domain of P'_\square into finitely many smaller rectangles. Then, for each smaller rectangle, $S = \{a \leq x \leq b, c \leq y \leq d\}$, we transform it to \mathbb{R}_+^2 creating a corresponding polynomial, $P''_S(x, y)$, and test criteria **PosCoeffs** and **SubPoly** to see whether this polynomial is positive. See Figure 7 for the transformation of a general rectangle, S , to \mathbb{R}_+^2 . Given this transformation, the polynomial, P''_S , is given by

$$\begin{aligned} P''_S(x, y) &= \sigma_{\frac{1}{b-a}, \frac{1}{d-c}} \left(P'_\square \left(\frac{1}{x} + a, \frac{1}{y} + c \right) x^{d'_x} y^{d'_y} \right) \\ &= P'_\square \left(\frac{1}{x + \frac{1}{b-a}} + a, \frac{1}{y + \frac{1}{d-c}} + c \right) \left(x + \frac{1}{b-a} \right)^{d'_x} \left(y + \frac{1}{d-c} \right)^{d'_y} \end{aligned} \quad (11)$$

where P'_\square is one of $P'_{NE}, P'_{NW}, P'_{SE}, P'_{SW}$, and $d'_z = \text{degree of } z \text{ in } P'_\square$ for $z = x, y$. Before we see the canonical subdivision algorithm let us see why this $P''_S(x, y)$ will give the desired result.

Proposition 3.4. *Let $P'_\square(x, y)$ be a polynomial, $d'_x = \deg_x(P'_\square)$, $d'_y = \deg_y(P'_\square)$, $0 \leq a < b$, and $0 \leq c < d$. Consider the polynomial P''_S as defined in (11). If $P''_S(x, y)$ is positive on \mathbb{R}_+^2 , then $P'_\square(x, y)$ is positive on the rectangle $S = \{a \leq x \leq b, c \leq y \leq d\}$.*

Proof. This proof follows the form of the proofs for Propositions 3.2 and 3.3. First, by definition of $P''(S)$, the fact that $P''_S(x, y) \geq 0$ for $x, y \geq 0$ means

$$P'_\square \left(\frac{1}{x + \frac{1}{b-a}} + a, \frac{1}{y + \frac{1}{d-c}} + c \right) \left(x + \frac{1}{b-a} \right)^{d'_x} \left(y + \frac{1}{d-c} \right)^{d'_y} \geq 0.$$

As in the previous proofs we may cancel $\left(x + \frac{1}{b-a} \right)^{d'_x} \left(y + \frac{1}{d-c} \right)^{d'_y}$ without reversing the inequality. Let $x' = x + \frac{1}{b-a}$ and $y' = y + \frac{1}{d-c}$, then

$$P'_\square \left(\frac{1}{x'} + a, \frac{1}{y'} + c \right) \geq 0$$

for $x' = x + \frac{1}{b-a} \geq \frac{1}{b-a}$ and $y' = y + \frac{1}{d-c} \geq \frac{1}{d-c}$. Next, let $x'' = \frac{1}{x'}$ and $y'' = \frac{1}{y'}$. Making this substitution yields

$$P'_\square (x'' + a, y'' + c) \geq 0$$

for $0 < x'' = \frac{1}{x'} \leq b - a$ and $0 < y'' = \frac{1}{y'} \leq d - c$. For the final substitution, let $x''' = x'' + a$ and $y''' = y'' + c$. Then

$$P'_\square (x''', y''') \geq 0$$

for $a < x''' = x'' + a \leq b$ and $c < y''' = y'' + c \leq d$. In other words, $P'_\square(x, y) \geq 0$ for $(x, y) \in S$. \square

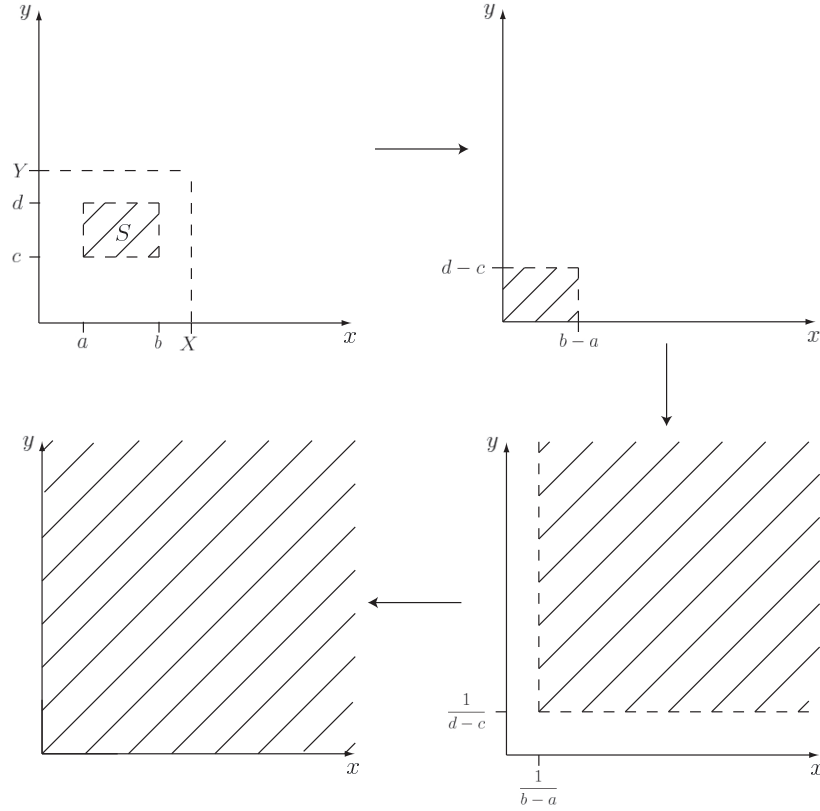

Figure 7: Transforming general rectangle, S , to \mathbb{R}_+^2

In principle any subdivision will work so long as we cover the entire finite rectangle. However, since the goal is to program the algorithm we need to specify a canonical subdivision. First we will simply divide into four equal regions. For each region we perform the above steps (transform the region and polynomial, apply criteria **PosCoeffs** and **SubPoly**). If we fail either criteria on a specific subregion, then we subdivide that subregion into four again and repeat. We continue to do this until we pass **PosCoeffs** or **SubPoly**, fail **LCoeff** or **Const** (and output **false**), or we reach some stopping condition and output **FAIL**. A stopping condition could be that we have subdivided N times, for some large N .

Before we summarize the positivity algorithm in the general n -dimensional case we must see the general **SubPoly** criteria. It was previously stated only in the case of 2 variables.

SubPoly- n : If the only negative coefficients in P_{\square} (including the constant term) are on terms of the form $x_r x_s$ then we check whether the quadratic form [10],

$$\sum_{\substack{i,j=1 \\ i \leq j}}^n a_{i,j} x_i x_j \quad (12)$$

where $a_{i,j}$ are coefficients of their respective terms in P_{\square} , is positive definite (i.e., is positive for all $\langle x_1, \dots, x_n \rangle \neq \langle 0, \dots, 0 \rangle$) using its corresponding matrix. The symmetric coefficient matrix is defined as: $A = (a'_{i,j})$, where $a'_{i,j} = a'_{j,i} = \frac{1}{2} a_{i,j}$ for all $i \neq j$, and $a'_{i,i} = a_{i,i}$ [12]. Given this matrix, we can equivalently think of the quadratic form as $\mathbf{x}A\mathbf{x}^T$, where $\mathbf{x} = \langle x_1, \dots, x_n \rangle$. Since A is a symmetric matrix, we know from the spectral theorem that it is diagonalizable by an orthonormal matrix, Q , so we have that $A = QDQ^T$ where D is a diagonal matrix. We can then rewrite the

quadratic form as:

$$\begin{aligned}\mathbf{x}A\mathbf{x}^T &= \mathbf{x}QDQ^\top \mathbf{x}^\top \\ &= \tilde{\mathbf{x}}D\tilde{\mathbf{x}}^\top.\end{aligned}$$

From this we easily see that the quadratic form is positive definite iff all eigenvalues of A are positive (i.e., A is positive definite). Then, if this quadratic “sub-polynomial” of P_\square is positive, P_\square itself is positive (since the other coefficients are positive).

We are now ready to summarize the algorithm in the n -dimensional case. Assume we have a polynomial $P \in \mathbb{R}[x_1, \dots, x_n]$, and want to test whether $P(x_1, \dots, x_n) \geq 0$ for $(x_1, \dots, x_n) \in \mathbb{R}_+^n$.

1. First cut \mathbb{R}_+^n into regions, similar to the NW , NE , SW , SE regions. For each variable we have 2 possibilities for its domain

$$0 \leq x_i \leq \bar{x} \quad \text{or} \quad \bar{x} \leq x_i < \infty.$$

A region is defined by making a choice for each variable, thus we have 2^n regions. The associated polynomial, P_\square , for each region is then created by substituting

$$x_i \text{ by } \begin{cases} x_i + \bar{x} & \text{if } \bar{x} \leq x_i < \infty \\ \frac{1}{x_i + \frac{1}{\bar{x}}} & \text{if } 0 \leq x_i \leq \bar{x} \end{cases}$$

in P , and then multiplying by $(x_i + \frac{1}{\bar{x}})^{d_{x_i}}$ if $0 \leq x_i \leq \bar{x}$.

2. For each region we check our 4 criteria **PosCoeffs**, **SubPoly- n** , **LCoeff**, and **Const**. If all 2^n polynomials pass **PosCoeffs** or **SubPoly- n** then we are done, and P is positive on \mathbb{R}_+^n . If any of the polynomials fail **LCoeff** or **Const** then we are also done because we know that there are values in \mathbb{R}_+^n for the variables which make P negative. Otherwise, we continue on to step 3 for the regions which fail **PosCoeffs** and **SubPoly- n** .
3. Assume we have a specific region (domains for each variable), R , which failed step 2. Then we create the polynomial P'_R by substituting $\frac{1}{x_i}$ for x_i in P if x_i is restricted to $\bar{x} \leq x_i < \infty$ in R , and then multiplying by $x_i^{d_{x_i}}$ for those variables which were substituted. This new polynomial will be restricted to the region R' , which is defined from R in the following manner: if $0 \leq x_i \leq \bar{x}$ in R , then x_i has the same restriction in R' ; otherwise, $\bar{x} \leq x_i < \infty$ in R , and then x_i is restricted to $0 < x_i \leq \frac{1}{\bar{x}}$ in R' . More formally, if $D = \{i : 0 \leq x_i \leq \bar{x} \text{ in } R\}$, and $\bar{D} = [n] \setminus D$ then

$$R' = \left(\prod_{i \in D} \{0 \leq x_i \leq \bar{x}\} \right) \times \left(\prod_{i \in \bar{D}} \left\{ 0 < x_i \leq \frac{1}{\bar{x}} \right\} \right)$$

- (a) Subdivide R' into 2^n equal regions, S_j , and for each region create the polynomial P'_{S_j} in the same manner as (11).
- (b) Test positivity of P'_{S_j} using criteria **PosCoeffs**, **SubPoly- n** , **LCoeff**, and **Const**. If P'_{S_j} passes **PosCoeffs** or **SubPoly- n** then we are done in region S_j and can continue checking the rest of the subregions of R' . If P'_{S_j} fails **LCoeff** or **Const** then we stop altogether because we know that there are values for the variables in \mathbb{R}_+^n which make P negative. Otherwise, go back to step 3(a) with region R' now replaced by S_j .
- (c) If we have recursed more than N times (for some choice of N), stop and output **FAIL**.

Before going on to the proof-of-concept for a specific difference equation and equilibrium let us see how to apply the polynomial positivity algorithm. We will see two examples, one in which **SubPoly** must be used, and one where subdivisions are necessary.

Example 3.1. Let $P(x, y) = x^2 - xy + y^2$ and $\bar{x} = 1$. First we subdivide \mathbb{R}_+^2 into the for regions NE ,

SW , NW , SE and get the following polynomials:

$$\begin{aligned} P_{NE}(x, y) &= \sigma_1(P) = x^2 - xy + y^2 + x + y + 1, \\ P_{SW}(x, y) &= \sigma_1\left(P\left(\frac{1}{x}, \frac{1}{y}\right) x^{d_x} y^{d_y}\right) = x^2 - xy + y^2 + x + y + 1, \\ P_{NW}(x, y) &= \sigma_{1,1}\left(P\left(\frac{1}{x}, y\right) x^{d_x}\right) = x^2 y^2 + 2x^2 y + 2xy^2 + x^2 + 3xy + y^2 + x + y + 1, \\ P_{SE}(x, y) &= \sigma_{1,1}\left(P\left(x, \frac{1}{y}\right) y^{d_y}\right) = x^2 y^2 + 2x^2 y + 2xy^2 + x^2 + 3xy + y^2 + x + y + 1. \end{aligned}$$

The polynomials $P_{NW}(x, y) = P_{SE}(x, y)$ have all positive coefficients, so they satisfy **PosCoeffs**. To see that $P_{NE}(x, y)$ (which equals $P_{SW}(x, y)$ in this example) is positive we must test criteria **SubPoly**.

The only negative coefficient in $P_{NE}(x, y)$ is on the xy term, so we look at the sub-polynomial $x^2 - xy + y^2$. The discriminant of this binary quadratic form is $4 \cdot 1 \cdot 1 - 1^2 = 3$, which is positive as needed. So we see that $P_{NE}(x, y)$ (and thus $P_{SW}(x, y)$) is positive by **SubPoly**.

In this example we don't have to do further subdivisions since $P_{NW}, P_{NE}, P_{SE}, P_{SW}$ are all positive. Therefore, we are done by Proposition 3.2. \diamond

Example 3.2. Let $P(x, y) = x^4 y - 5x^3 y + 10x^2 y + x + y$ and $\bar{x} = 1$. First we subdivide \mathbb{R}_+^2 into the for regions NE , SW , NW , SE and get the following polynomials:

$$\begin{aligned} P_{NE}(x, y) &= \sigma_1(P) = x^4 y + x^4 - x^3 y - x^3 + x^2 y + 2x^2 + 9xy + 11x + 7y + 8, \\ P_{SW}(x, y) &= \sigma_1\left(P\left(\frac{1}{x}, \frac{1}{y}\right) x^{d_x} y^{d_y}\right) = x^4 + 4x^3 + x^2 y + 17x^2 + 2xy + 21x + y + 8, \\ P_{NW}(x, y) &= \sigma_{1,1}\left(P\left(\frac{1}{x}, y\right) x^{d_x}\right) \\ &= x^4 y + x^4 + 4x^3 y + 4x^3 + 16x^2 y + 17x^2 + 19xy + 21x + 7y + 8, \\ P_{SE}(x, y) &= \sigma_{1,1}\left(P\left(x, \frac{1}{y}\right) y^{d_y}\right) = x^4 - x^3 + x^2 y + 2x^2 + 2xy + 11x + y + 8. \end{aligned}$$

In this example we see that $P_{SW}(x, y)$ and $P_{NW}(x, y)$ pass criteria **PosCoeffs** since all coefficients are positive. For the other two regions we will need to subdivide because the negative coefficients are not on the term xy .

Let us first examine SE . We need to create the polynomial $P'_{SE}(x, y)$ as in 10:

$$\begin{aligned} P'_{SE}(x, y) &= P\left(\frac{1}{x}, y\right) x^{d_x} \\ &= x^4 y + 10x^2 y + x^2 - 5xy + y \quad \text{restricted to } 0 < x \leq 1, 0 \leq y \leq 1. \end{aligned}$$

Then we subdivide the region $0 < x \leq 1, 0 \leq y \leq 1$ into four equal rectangles:

$$\begin{aligned} S_1 &= \left\{0 < x \leq \frac{1}{2}, 0 \leq y \leq \frac{1}{2}\right\}, & S_2 &= \left\{0 < x \leq \frac{1}{2}, \frac{1}{2} \leq y \leq 1\right\}, \\ S_3 &= \left\{\frac{1}{2} \leq x \leq 1, 0 \leq y \leq \frac{1}{2}\right\}, & S_4 &= \left\{\frac{1}{2} \leq x \leq 1, \frac{1}{2} \leq y \leq 1\right\}, \end{aligned}$$

and create four associated polynomials using (11):

$$\begin{aligned}
P''_{S_1}(x, y) &= x^4 + 3x^3 + x^2y + 6x^2 + 4xy + 20x + 4y + 25, \\
P''_{S_2}(x, y) &= \frac{1}{2}x^4y + 2x^4 + \frac{3}{2}x^3y + 6x^3 + 3x^2y + 10x^2 + \\
&\quad + 10xy + 32x + \frac{25}{2}y + 42, \\
P''_{S_3}(x, y) &= \frac{1}{4}x^4y + \frac{25}{16}x^4 + 3x^3y + 20x^3 + 13x^2y + \\
&\quad + 96x^2 + 24xy + 196x + 16y + 144, \\
P''_{S_4}(x, y) &= \frac{25}{32}x^4y + \frac{21}{8}x^4 + 10x^3y + 34x^3 + 48x^2y + \\
&\quad + 166x^2 + 98xy + 344x + 72y + 256.
\end{aligned}$$

All four polynomials for the subdivision of SE are positive by **PosCoeffs**, therefore $P'_{SE}(x, y) \geq 0$, and by Proposition 3.3 we see that $P(x, y) \geq 0$ on the region SE .

Now let us look at P_{NE} . Create P'_{NE} as indicated by (10):

$$\begin{aligned}
P'_{NE}(x, y) &= P\left(\frac{1}{x}, \frac{1}{y}\right) x^{d_x} y^{d_y} \\
&= 8x^4y + 7x^4 + 11x^3y + 9x^3 + 2x^2y + x^2 - xy - x + y + 1 \\
&\quad \text{restricted to } 0 < x \leq 1, 0 \leq y \leq 1.
\end{aligned}$$

Subdivide the region $0 < x \leq 1, 0 \leq y \leq 1$ into the same $S_1, S_2, S_3,$ and S_4 as above, and create the polynomials P''_{S_i} , this time from P'_{NE} :

$$\begin{aligned}
P''_{S_1}(x, y) &= x^4y + 3x^4 + 7x^3y + 21x^3 + 19x^2y + 58x^2 + \\
&\quad + 33xy + 105x + 37y + 120, \\
P''_{S_2}(x, y) &= \frac{3}{2}x^4y + 4x^4 + \frac{21}{2}x^3y + 28x^3 + 29x^2y + 78x^2 + \\
&\quad + \frac{105}{2}xy + 144x + 60y + 166, \\
P''_{S_3}(x, y) &= \frac{37}{16}x^4y + \frac{15}{2}x^4 + \frac{115}{4}x^3y + \frac{375}{4}x^3 + 142x^2y + \\
&\quad + 463x^2 + 320xy + 1040x + 272y + 880, \\
P''_{S_4}(x, y) &= \frac{15}{4}x^4y + \frac{83}{8}x^4 + \frac{375}{8}x^3y + 130x^3 + \frac{463}{2}x^2y + \\
&\quad + 642x^2 + 520xy + 1440x + 440y + 1216.
\end{aligned}$$

As before, all four subdivision polynomials pass **PosCoeffs**, and so they are positive. Therefore, by Propositions 3.2, 3.3, and 3.4 we know that $P(x, y) \geq 0$ for $(x, y) \in \mathbb{R}_+^2$. \diamond

4 Proof of Concept

We have now seen the full algorithm to prove GAS of equilibrium points of rational difference equations. However, there is no reason a priori that this algorithm is applicable. It could be the case that no such K (see Section 2 for a definition of K) exists, and this algorithm would be useless.

We will now see that this technique does, in fact, work to prove global asymptotic stability of an equilibrium of a particular rational difference equation. The proof of the following theorem to establish global asymptotic stability will go through the procedure outlined in the previous sections.

Theorem 4.1. *For the rational difference equation*

$$x_{n+1} = \frac{4 + x_n}{1 + x_{n-1}}, \quad (13)$$

the equilibrium, $\bar{x} = 2$, is GAS.

Proof. We will prove that $K = 5$ satisfies (4) from Theorem 1.1. From the rational difference equation, the equilibrium $\bar{x} = 2$, and $K = 5$ we get the polynomial, $P := P_{(2,2),5}((x_1, x_2))$, as defined in (6):

$$\begin{aligned}
P = & 25x_1^8x_2^4 + 340x_1^8x_2^3 + 1606x_1^8x_2^2 + 3060x_1^8x_2 + 2025x_1^8 + 60x_1^7x_2^5 + 1158x_1^7x_2^4 + \\
& + 8460x_1^7x_2^3 + 28936x_1^7x_2^2 + 45848x_1^7x_2 + 27090x_1^7 + 71x_1^6x_2^6 + 1418x_1^6x_2^5 + \\
& + 11229x_1^6x_2^4 + 53362x_1^6x_2^3 + 147345x_1^6x_2^2 + 207144x_1^6x_2 + 113103x_1^6 + 72x_1^5x_2^7 + \\
& + 1420x_1^5x_2^6 + 9012x_1^5x_2^5 + 20174x_1^5x_2^4 + 24716x_1^5x_2^3 + 74718x_1^5x_2^2 + 163032x_1^5x_2 + \\
& + 108952x_1^5 + 47x_1^4x_2^8 + 1276x_1^4x_2^7 + 11120x_1^4x_2^6 + 25528x_1^4x_2^5 - 118780x_1^4x_2^4 - \\
& - 688300x_1^4x_2^3 - 1195361x_1^4x_2^2 - 790736x_1^4x_2 - 148969x_1^4 + 12x_1^3x_2^9 + 538x_1^3x_2^8 + \\
& + 7854x_1^3x_2^7 + 45864x_1^3x_2^6 + 53604x_1^3x_2^5 - 515564x_1^3x_2^4 - 2066454x_1^3x_2^3 - \\
& - 2469564x_1^3x_2^2 - 207576x_1^3x_2 + 833882x_1^3 + x_1^2x_2^{10} + 86x_1^2x_2^9 + 2109x_1^2x_2^8 + \\
& + 22070x_1^2x_2^7 + 102117x_1^2x_2^6 + 105526x_1^2x_2^5 - 695269x_1^2x_2^4 - 1867364x_1^2x_2^3 + \\
& + 785343x_1^2x_2^2 + 6256056x_1^2x_2 + 4716817x_1^2 + 4x_1x_2^{10} + 198x_1x_2^9 + 3530x_1x_2^8 + \\
& + 29636x_1x_2^7 + 117218x_1x_2^6 + 136288x_1x_2^5 - 289440x_1x_2^4 + 253318x_1x_2^3 + \\
& + 5674806x_1x_2^2 + 11634024x_1x_2 + 7054300x_1 + 4x_2^{10} + 148x_2^9 + 2145x_2^8 + 15348x_2^7 + \\
& + 53870x_2^6 + 69340x_2^5 + 30579x_2^4 + 801874x_2^3 + 3802411x_2^2 + 6262908x_2 + 3488704.
\end{aligned}$$

The goal is to prove that this polynomial is positive when all variables are positive. Recall that we created this polynomial by taking the numerator of

$$\|\mathcal{X} - \bar{\mathcal{X}}\|^2 - \|Q^5(\mathcal{X}) - \bar{\mathcal{X}}\|^2,$$

where $Q(\mathcal{X})$ is the map

$$Q\left(\begin{bmatrix} x_n \\ x_{n-1} \end{bmatrix}\right) = \begin{bmatrix} \frac{4+x_n}{1+x_{n-1}} \\ x_n \end{bmatrix}.$$

Now we run the polynomial positivity algorithm described in Section 3 to prove that this polynomial is positive. If the polynomial is positive when all variables are positive then the equilibrium, $\bar{x} = 2$, is GAS for the original difference equation by Theorem 1.1.

First we will prove that $P > 0$ in the region NE . We make the polynomial P_{NE} by substituting $x_1 = x_1 + 2$ and $x_2 = x_2 + 2$ into P . See the Appendix in [5] for P_{NE} and the rest of the polynomials as they will be omitted from this paper. Now we need to prove that $P_{NE} > 0$ in the region \mathbb{R}_+^2 except when all variables are simultaneously zero. The only negative coefficient is on the term x_1x_2 , so we can use the discriminant method. The binary quadratic form that we must show is positive definite is

$$349366689x_1^2 - 6980904x_1x_2 + 318700575x_2^2.$$

Its discriminant is $d = 445324725659927484$ which is positive, so by **SubPoly** $P_{NE} > 0$ in \mathbb{R}_+^2 .

Now we will prove $P > 0$ in the region NW . Create the polynomial P_{NW} by substituting $x_1 = 1/x_1$, multiplying by $x_1^{d_{x_1}} = x_1^8$, and then translating x_1 by $1/2$ to the left, and x_2 by 2 to the left. All coefficients in P_{NW} are positive, and the constant term is zero. There is no proper subset of the variables for which setting them all equal zero yields the zero polynomial. Therefore, P_{NW} is zero only when all variables are zero, and so $P > 0$ in NW .

Next, we will prove $P > 0$ in the region SE . First make the polynomial P_{SE} by substituting $x_2 = 1/x_2$, multiplying by $x_2^{d_{x_2}} = x_2^{10}$, and then translating x_1 by 2 to the left and x_2 by $1/2$ to the left. Now we need to prove that $P_{SE} > 0$ in the region \mathbb{R}_+^2 except when all variables are simultaneously zero. All coefficients are positive, and the constant term is zero. There is no proper subset of the variables for which setting them all equal zero yields the zero polynomial. Therefore, P_{SE} is zero only when all variables are zero, and then $P > 0$ in the region SE .

Finally, we must prove $P > 0$ in the region SW . Make the polynomial P_{SW} by substituting $x_1 = 1/x_1$ and $x_2 = 1/x_2$, multiplying by $x_1^{d_{x_1}} = x_1^8$ and $x_2^{d_{x_2}} = x_2^{10}$, and then translating both variables by $1/2$

to the left. Now we need to prove that $P_{SW} > 0$ in the region \mathbb{R}_+^2 except when all variables are simultaneously zero. As in the region NE the term x_1x_2 has a negative coefficient (and that is the only such coefficient), so we will use the discriminant method again. The binary quadratic form that must be positive is

$$\frac{349366689}{16384}x_1^2 - \frac{872613}{2048}x_1x_2 + \frac{318700575}{16384}x_2^2$$

The discriminant is $d = \frac{111331181414981871}{67108864}$, which is positive. Then, by **SubPoly**, P_{SW} is positive in \mathbb{R}_+^2 , so $P > 0$ in the region SW .

Since $P > 0$ in all four regions, NE , NW , SE , and SW , the K value 5 is proven to work for the rational difference equation $x_{n+1} = \frac{4+x_n}{1+x_{n-1}}$ \square

We can now see that the algorithm is indeed applicable. However, it wouldn't be possible without programming the algorithm. For large K values, even $K \geq 3$, the polynomials are near impossible to deal with by hand. For this reason there is a maple package, described below in Section 6.

5 Results

In this section we present the results that our algorithm can prove in full generality. So far we have considered rational difference equations with specific numerical coefficients. In this section, we consider the case where the coefficients are additional variables, which are required to be positive. So the polynomial that we create is now a polynomial in the variables $x_n, x_{n-1}, \dots, x_{n-k}$ as well as all of the coefficient variables. We must point out that our algorithm will only apply when the equilibrium can be expressed as a rational function of the coefficient variables. For the proofs of the results found in this table see [5].

The equation numbers given in the following table match up with those in [2], however the difference equations themselves may look different. The parameters presented here are to guarantee that the equilibria will be rational functions in the parameters.

Eqn #	$x_{n+1} =$	Parameter Values	Findings
2	$\frac{M^2}{x_n}$	$M \in \mathbb{R}$	$\bar{x} = M $ is not LAS
3	$\frac{M^2}{x_{n-1}}$	$M \in \mathbb{R}$	$\bar{x} = M $ is not LAS
5	βx_n	$0 \leq \beta < 1$ $1 \leq \beta$	$\bar{x} = 0$ is GAS $\bar{x} = 0$ is not LAS
9	γx_{n-1}	$0 \leq \gamma < 1$ $1 \leq \gamma$	$\bar{x} = 0$ is GAS $\bar{x} = 0$ is not LAS
17	$\frac{1}{4} \frac{M^2 - 1}{1 + x_n}$	$M - 1 > 0, M + 1 > 0$ $M - 1 < 0, M + 1 < 0$	$\bar{x} = \frac{1}{2}(M - 1)$ is GAS $\bar{x} = -\frac{1}{2}(M + 1)$ is GAS
23	$\frac{\beta x_n}{1 + x_n}$	$0 < \beta \leq 1$ $1 < \beta$	$\bar{x} = 0$ is GAS $\bar{x} = \beta - 1$ is GAS
29	$\frac{x_{n-1}}{A + x_n}$	$0 < A < 1$ $1 < A$	$\bar{x} = 1 - A$ is not LAS $\bar{x} = 0$ is GAS
30	$\frac{x_{n-1}}{A + x_{n-1}}$	$0 < A < 1$ $1 < A$	$\bar{x} = 1 - A$ is GAS $\bar{x} = 0$ is GAS
41	$\alpha + \beta x_n$	$0 \leq \beta < 1$	$\bar{x} = \frac{\alpha}{1 - \beta}$ is GAS
42	$q + \frac{1}{4} \frac{M^2 - q^2}{x_n}$	$M - q < 0, M + q < 0, q > 0$ $M - q > 0, M + q > 0, q > 0$	$\bar{x} = -\frac{1}{2}(M - q)$ is GAS $\bar{x} = \frac{1}{2}(M + q)$ is GAS
65	$\frac{1}{4} \frac{M^2 - q^2 + 4x_n}{1 + q + x_n}$	$M - q > 0, M + q > 0, q > -1$ $M - q < 0, M + q < 0, q > -1$	$\bar{x} = \frac{1}{2}(M - q)$ is GAS $\bar{x} = -\frac{1}{2}(M + q)$ is GAS
109	$\frac{x_{n-1}}{A + Bx_n + x_{n-1}}$	$1 < A$	$\bar{x} = 0$ is GAS

In addition to the results in the above table our algorithm can be used to prove GAS of many rational difference equations in which the coefficients have specific numerical values. See the Web Books on the web page that accompanies this paper

<http://math.rutgers.edu/~eahogan/GAS.html>

6 Maple Code

In addition to the Web Books, there is a Maple package to accompany this paper which can also be found on the above web page. The three most useful procedures are ProveK, Prove, and WebBook. ProveK will use our algorithm to show that a given K value works to prove that the unique equilibrium of a particular rational difference equation is GAS. Prove utilizes ProveK to find the K value for a particular rational difference equation up to a given threshold. WebBook takes in a rational difference equation with variables for coefficients and proves GAS for a specified number of random choices for the coefficients. There is a Help function (type Help() to see a list of all procedures, and Help(⟨procedure name⟩) to get help on a specific procedure). In the help for each procedure, a sample is given for how to use it.

7 Conclusion

In Sections 2 and 3 we have seen both parts of our new GAS algorithm: first reducing the problem to proving that a polynomial is positive, and then proving polynomial positivity. Putting the two together we now have a completely algorithmic approach to proving GAS of a given rational difference equation.

Inputs:

R - rational function in $k + 1$ variables
 \bar{x} - equilibrium, solution to $\bar{x} = R(\bar{x}, \dots, \bar{x})$
 $MaxK$ - a maximum K value to try

Outputs:

true if \bar{x} is proven to be GAS for $x_{n+1} = R(x_n, x_{n-1}, \dots, x_{n-k})$
false if \bar{x} is not LAS for $x_{n+1} = R(x_n, x_{n-1}, \dots, x_{n-k})$
FAIL if $MaxK$ was not high enough.

Procedure:

1. Check local asymptotic stability using the linearized stability theorem. If not LAS then output **false**. If LAS then continue to Step 2.
2. Conjecture a K value that satisfies Theorem 1.1 using the procedure outlined in Section 2.
3. Apply the n -dimensional polynomial positivity algorithm outlined at the end of Section 3. If the conjectured K value was proven to work, output **true**. If the conjectured K value was proven *not* to work (P_K failed **LCoeff** or **Const**), or the algorithm reached a recursion limit, continue to Step 4.
4. If $K < MaxK$, increment K by 1 and return to Step 3. If $K \geq MaxK$ then output **FAIL**.

This algorithm now gives us a completely automatic proof machine for global asymptotic stability. As was mentioned in the introduction, this problem has historically not been approached in any kind of systematic fashion. Many of the theorems found in [2, 9] for proving GAS, were developed as generalizations of techniques used to prove GAS of specific difference equations. This meant that given a particular difference equation, proving its equilibrium is GAS would amount to trying to apply various known theorems. Or, one may have to create a new theorem just to prove GAS of one particular rational difference equation. There may not have been a clear cut path leading to the proof. We believe that our new algorithm can serve as that path. Of course, given a difference equation that is known to be GAS, our algorithm may not always be able to prove it. However, we believe that it is much more widely applicable than any one previously known theorem guaranteeing global asymptotic stability.

8 Acknowledgements

This material is based upon work supported by the U.S. Department of Homeland Security under Grant Award Number 2007-ST-104-000006. The views and conclusions contained in this document are those of the authors and should not be interpreted as necessarily representing the official policies, either expressed or implied, of the U.S. Department of Homeland Security.

References

- [1] D. S. Arnon, G. E. Collins, and S. McCallum, Cylindrical algebraic decomposition I: The basic algorithm, *SIAM Journal on Computing*, **13**(4), (1984), 865–877.
- [2] E. Camouzis and G. Ladas, *Dynamics of Third Order Rational Difference Equations*, Chapman and Hall/CRC press (2008).
- [3] S. Elaydi, *Introduction to Difference Equations*, Springer (2000).
- [4] J. Hale and H. Kocak, *Dynamics & Bifurcations*, Springer-Verlag (1991).
- [5] E. Hogan, *Experimental methods applied to the study of non-linear recurrences*, Ph.D. thesis, Rutgers, The State University of New Jersey (2011).
- [6] H. Hong and D. Jakuš, Testing positiveness of polynomials, *Journal of Automatic Reasoning*, **21**(1), (1998), 23–38.
- [7] V. Kocic and G. Ladas, *Global Behavior of Nonlinear Difference Equations of Higher Order with Applications*, Kluwer Academic Publishers (1993).
- [8] N. Kruse and T. Nesemann, Global asymptotic stability in some discrete dynamical systems, *Journal of Mathematical Analysis and Applications*, **235**, (1999), 151–158.
- [9] M. R. S. Kulenović and G. Ladas, *Dynamics of Second Order Rational Difference Equations*, Chapman and Hall/CRC press (2001).
- [10] T. Lam, *Introduction to Quadratic Forms over Fields*, vol. 67 of *Graduate Studies in Mathematics*, American Mathematical Society (2004).
- [11] M. Martelli, *Introduction to Discrete Dynamical Systems*, John Wiley & Sons (1999).
- [12] O. T. O’Meara, *Introduction to Quadratic Forms*, Springer-Verlag (1971).