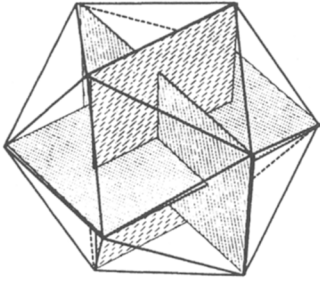

1 The Theory of Linear Difference Equations Applied to Population Growth

For we will always have as 5 is to 8 so is 8 to 13, practically, and as 8 is to 13, so is 13 to 21 almost. I think that the seminal faculty is developed in a way analogous to this proportion which perpetuates itself, and so in the flower is displayed a pentagonal standard, so to speak. I let pass all other considerations which might be adduced by the most delightful study to establish this truth.

J. Kepler, (1611). *Sterna seu de nive sexangule, Opera*, ed. Christian Frisch, tome 7, (Frankfurt à Main, Germany: Heyden & Zimmer, 1858–1871), pp. 722–723.

The early Greeks were fascinated by numbers and believed them to hold special magical properties. From the Greeks' special blend of philosophy, mathematics, numerology, and mysticism, there emerged a foundation for the real number system upon which modern mathematics has been built. A preoccupation with aesthetic beauty in the Greek civilization meant, among other things, that architects, artisans, and craftsmen based many of their works of art on geometric principles. So it is that in the stark ruins of the Parthenon many regularly spaced columns and structures capture the essence of the *golden mean*, which derives from the *golden rectangle*.

Considered to have a most visually pleasing proportion, the *golden rectangle* has sides that bear the ratio $\tau = 1:1.618033\dots$. The problem of subdividing a line segment into this so-called *extreme and mean ratio* was a classical problem in Greek geometry, appearing in the *Elements* of Euclid (circa 300 B.C.). It was recognized then and later that this *divine proportion*, as Fra Luca Pacioli (1509) called it, appears in numerous geometric figures, among them the pentagon, and the polyhedral icosahedron (see Figure 1.1).



(a)

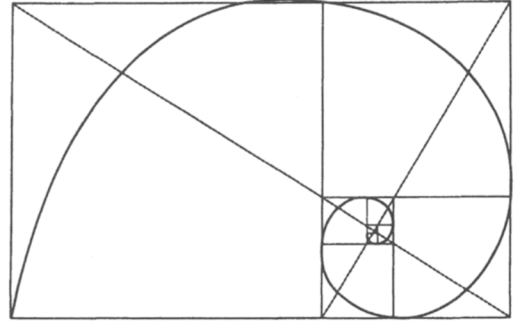

(b)

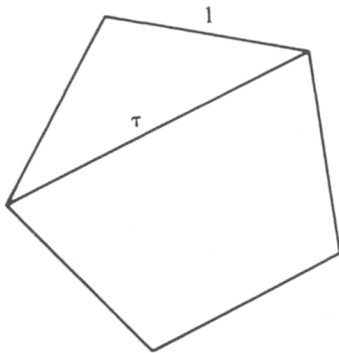

(c)

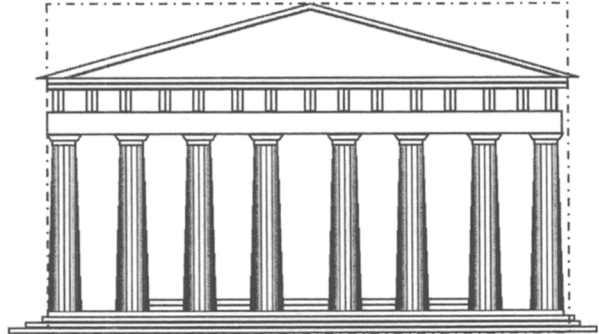

(d)

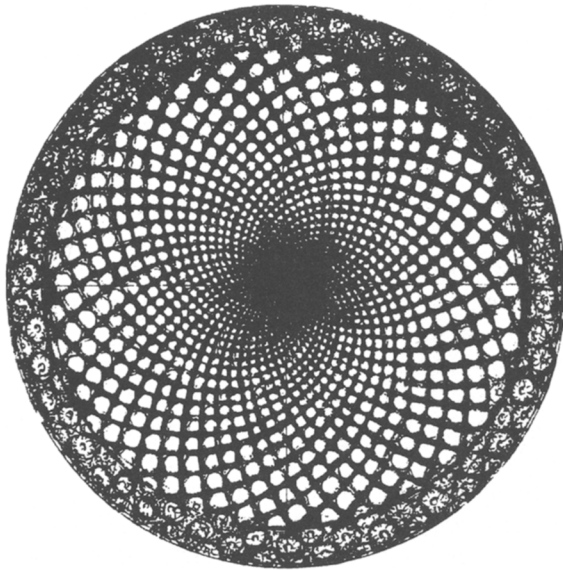

(e)

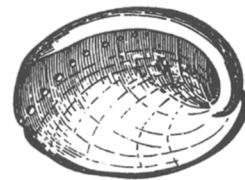

(f)

About fifteen hundred years after Euclid, Leonardo of Pisa (1175–1250), an Italian mathematician more affectionately known as Fibonacci (“son of good nature”), proposed a problem whose solution was a series of numbers that eventually led to a reincarnation of τ . It is believed that Kepler (1571–1630) was the first to recognize and state the connection between the *Fibonacci numbers* (0, 1, 1, 2, 3, 5, 8, 13, 21, . . .), the golden mean, and certain aspects of plant growth.

Kepler observed that successive elements of the Fibonacci sequence satisfy the following *recursion relation*

$$n_{k+2} = n_k + n_{k+1}, \quad (1)$$

i.e., each member equals the sum of its two immediate predecessors.¹ He also noted that the ratios 2:1, 3:2, 5:3, 8:5, 13:8, . . . approach the value of τ .² Since then, manifestations of the golden mean and the Fibonacci numbers have appeared in art, architecture, and biological form. The *logarithmic spirals* evident in the shells of certain mollusks (e.g., abalone, of the family *Haliotidae*) are figures that result from growth in size without change in proportion and bear a relation to successively inscribed golden rectangles. The regular arrangement of leaves or plant parts along the stem, apex, or flower of a plant, known as *phyllotaxis*, captures the Fibonacci numbers in a succession of helices (called *parastichies*); a striking example is the arrangement of seeds on a ripening sunflower. Biologists have not yet agreed conclu-

1. The values n_0 and n_1 are defined to be 0 and 1.

2. Certain aspects of the formulation and analysis of the recursion relation (1) governing Fibonacci numbers are credited to the French mathematician Albert Girard, who developed the algebraic notation in 1634, and to Robert Simson (1753) of the University of Glasgow, who recognized ratios of successive members of the sequence as τ and as continued fractions (see problem 12).

Figure 1.1 The golden mean τ appears in a variety of geometric forms that include: (a) Polyhedra such as the icosahedron, a Platonic solid with 20 equilateral triangle faces (τ = ratio of sides of an inscribed golden rectangle; three golden rectangles are shown here). (b) The golden rectangle and every rectangle formed by removing a square from it. Note that corners of successive squares can be connected by a logarithmic spiral). (c) A regular pentagon (τ = the ratio of lengths of the diagonal and a side). (d) The approximate proportions of the Parthenon (dotted line indicates a golden rectangle). (e) Geometric designs such as spirals that result from the arrangement of leaves, scales, or florets on plants (shown here on the head of a sunflower). The number of spirals running in opposite directions quite often bears one of the numerical ratios 2/3, 3/5, 5/8, 8/13, 13/21, 21/34, 34/5, . . . [see R. V. Jean (1984, 86)];

note that these are the ratios of successive Fibonacci numbers. (f) Logarithmic spirals (such as those obtained in (b) are common in shells such as the abalone *Haliotis*, where each increment in size is similar to the preceding one. See D. W. Thompson (1974) for an excellent summary. [(a and b) from M. Gardner (1961), *The Second Scientific American Book of Mathematical Puzzles and Diversions*, pp. 92–93. Copyright 1961 by Martin Gardner. Reprinted by permission of Simon & Schuster, Inc., N.Y., N.Y. (d) from G. Gromort (1947), *Histoire abrégée de l'Architecture en Grèce et à Rome*, Fig 43 on p. 75, Vincent Fréal & Cie, Paris, France. (e) from S. Colman (1971), *Nature's Harmonic Unity*, plate 64, p. 91; Benjamin Blom, N.Y. (reprinted from the 1912 edition). (f) D. Thompson (1961), *On Growth and Form* (abridged ed.) figure 84, p. 186. Reprinted by permission of Cambridge University Press, New York.]

sively on what causes these geometric designs and patterns in plants, although the subject has been pursued for over three centuries.²

Fibonacci stumbled unknowingly onto the esoteric realm of τ through a question related to the growth of rabbits (see problem 14). Equation (1) is arguably the first mathematical idealization of a biological phenomenon phrased in terms of a recursion relation, or in more common terminology, a *difference equation*.

Leaving aside the mystique of golden rectangles, parastichies, and rabbits, we find that in more mundane realms, numerous biological events can be idealized by models in which similar discrete equations are involved. Typically, populations for which difference equations are suitable are those in which adults die and are totally replaced by their progeny at fixed intervals (i.e., generations do not overlap). In such cases, a difference equation might summarize the relationship between population density at a given generation and that of preceding generations. Organisms that undergo abrupt changes or go through a sequence of stages as they mature (i.e., have discrete life-cycle stages) are also commonly described by difference equations.

The goals of this chapter are to demonstrate how equations such as (1) arise in modeling biological phenomena and to develop the mathematical techniques to solve the following problem: given particular starting population levels and a recursion relation, predict the population level after an arbitrary number of generations have elapsed. (It will soon be evident that for a linear equation such as (1), the mathematical sophistication required is minimal.)

To acquire a familiarity with difference equations, we will begin with two rather elementary examples: cell division and insect growth. A somewhat more elaborate problem we then investigate is the propagation of annual plants. This topic will furnish the opportunity to discuss how a slightly more complex model is derived. Sections 1.3 and 1.4 will outline the method of solving certain linear difference equations. As a corollary, the solution of equation (1) and its connection to the golden mean will emerge.

1.1 BIOLOGICAL MODELS USING DIFFERENCE EQUATIONS

Cell Division

Suppose a population of cells divides synchronously, with each member producing a daughter cells.³ Let us define the number of cells in each generation with a subscript, that is, M_1, M_2, \dots, M_n are respectively the number of cells in the first, second, . . . , n th generations. A simple equation relating successive generations is

$$M_{n+1} = aM_n. \quad (2)$$

2. An excellent summary of the phenomena of phyllotaxis and the numerous theories that have arisen to explain the observed patterns is given by R. V. Jean (1984). His book contains numerous suggestions for independent research activities and problems related to phyllotaxis. See also Thompson (1942).

3. Note that for real populations only $a > 0$ would make sense; $a < 0$ is unrealistic, and $a = 0$ would be uninteresting.

Let us suppose that initially there are M_0 cells. How big will the population be after n generations? Applying equation (2) recursively results in the following:

$$M_{n+1} = a(aM_{n-1}) = a[a(aM_{n-2})] = \cdots = a^{n+1}M_0. \quad (3)$$

Thus, for the n th generation

$$M_n = a^n M_0. \quad (4)$$

We have arrived at a result worth remembering: The solution of a simple linear difference equation involves an expression of the form (some number) ^{n} , where n is the generation number. (This is true in general for linear difference equations.) Note that the magnitude of a will determine whether the population grows or dwindles with time. That is,

$$\begin{aligned} |a| > 1 & \quad M_n \text{ increases over successive generations,} \\ |a| < 1 & \quad M_n \text{ decreases over successive generations,} \\ a = 1 & \quad M_n \text{ is constant.} \end{aligned}$$

An Insect Population

Insects generally have more than one stage in their life cycle from progeny to maturity. The complete cycle may take weeks, months, or even years. However, it is customary to use a single generation as the basic unit of time when attempting to write a model for insect population growth. Several stages in the life cycle can be depicted by writing several difference equations. Often the system of equations condenses to a single equation in which combinations of all the basic parameters appear.

As an example consider the reproduction of the poplar gall aphid. Adult female aphids produce galls on the leaves of poplars. All the progeny of a single aphid are contained in one gall (Whitham, 1980). Some fraction of these will emerge and survive to adulthood. Although generally the capacity for producing offspring (fecundity) and the likelihood of surviving to adulthood (survivorship) depends on their environmental conditions, on the quality of their food, and on the population sizes, let us momentarily ignore these effects and study a naive model in which all parameters are constant.

First we define the following:

$$\begin{aligned} a_n &= \text{number of adult female aphids in the } n\text{th generation,} \\ p_n &= \text{number of progeny in the } n\text{th generation,} \\ m &= \text{fractional mortality of the young aphids,} \\ f &= \text{number of progeny per female aphid,} \\ r &= \text{ratio of female aphids to total adult aphids.} \end{aligned}$$

Then we write equations to represent the successive populations of aphids and use these to obtain an expression for the number of adult females in the n th generation if initially there were a_0 females:

Stage 2: Definitions and Assumptions

We first collect all the parameters and constants specified in the problem. Next we define the variables. At that stage it will prove useful to consult a rough sketch such as Figure 1.2.

Parameters:

- γ = number of seeds produced per plant in August,
- α = fraction of one-year-old seeds that germinate in May,
- β = fraction of two-year-old seeds that germinate in May,
- σ = fraction of seeds that survive a given winter.

In defining the variables, we note that the seed bank changes *several times* during the year as a result of (1) germination of some seeds, (2) production of new seeds, and (3) aging of seeds and partial mortality. To simplify the problem we make the following assumption: Seeds older than two years are no longer viable and can be neglected.

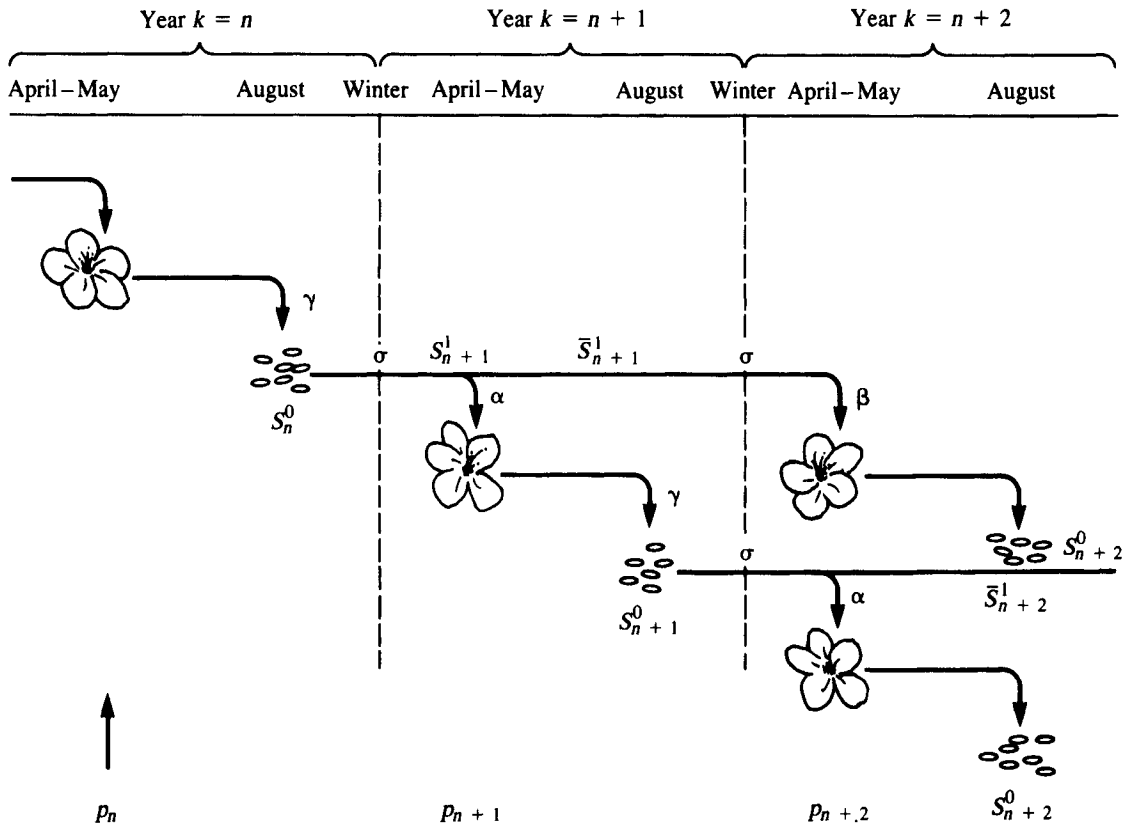

Figure 1.2 Annual plants produce γ seeds per plant each summer. The seeds can remain in the ground for up to two years before they germinate in the springtime. Fractions α of the one-year-old and β

of the two-year-old seeds give rise to a new plant generation. Over the winter seeds age, and a certain proportion of them die. The model for this system is discussed in Section 1.2.

Consulting Figure 1.2, let us keep track of the various quantities by defining

p_n = number of plants in generation n ,

S_n^1 = number of one-year-old seeds in April (before germination),

S_n^2 = number of two-year-old seeds in April (before germination),

\bar{S}_n^1 = number of one-year-old seeds left in May (after some have germinated),

\bar{S}_n^2 = number of two-year-old seeds left in May (after some have germinated),

S_n^0 = number of new seeds produced in August.

Later we will be able to eliminate some of these variables. In this first attempt at formulating the equations it helps to keep track of all these quantities. Notice that superscripts refer to age of seeds and subscripts to the year number.

Stage 3: The Equations

In May, a fraction α of one-year-old and β of two-year-old seeds produce the plants. Thus

$$p_n = \left(\begin{array}{l} \text{plants from} \\ \text{one-year-old seeds} \end{array} \right) + \left(\begin{array}{l} \text{plants from} \\ \text{two-year-old seeds} \end{array} \right),$$

$$p_n = \alpha S_n^1 + \beta S_n^2. \quad (9a)$$

The seed bank is reduced as a result of this germination. Indeed, for each age class, we have

$$\text{seeds left} = \left(\begin{array}{l} \text{fraction not} \\ \text{germinated} \end{array} \right) \times \left(\begin{array}{l} \text{original number} \\ \text{of seeds in April} \end{array} \right).$$

Thus

$$\bar{S}_n^1 = (1 - \alpha)S_n^1, \quad (9b)$$

$$\bar{S}_n^2 = (1 - \beta)S_n^2. \quad (9c)$$

In August, new (0-year-old) seeds are produced at the rate of γ per plant:

$$S_n^0 = \gamma p_n. \quad (9d)$$

Over the winter the seed bank changes by mortality and aging. Seeds that were new in generation n will be one year old in the next generation, $n + 1$. Thus we have

$$S_{n+1}^1 = \sigma S_n^0, \quad (9e)$$

$$S_{n+1}^2 = \sigma \bar{S}_n^1. \quad (9f)$$

Stage 4: Condensing the Equations

We now use information from equations (9a–f) to recover a set of two equations linking successive plant and seed generations. To do so we observe that by using equation (9d) we can simplify (9e) to the following:

$$S_{n+1}^1 = \sigma(\gamma p_n). \quad (10)$$

Similarly, from equation (9b) equation (9f) becomes

$$S_{n+1}^2 = \sigma(1 - \alpha)S_n^1. \tag{11}$$

Now let us rewrite equation (9a) for generation $n + 1$ and make some substitutions:

$$p_{n+1} = \alpha S_{n+1}^1 + \beta S_{n+1}^2. \tag{12}$$

Using (10), (11), and (12) we arrive at a *system* of two equations in which plants and one-year-old seeds are coupled:

$$p_{n+1} = \alpha\sigma\gamma p_n + \beta\sigma(1 - \alpha)S_n^1, \tag{13a}$$

$$S_{n+1}^1 = \sigma\gamma p_n. \tag{13b}$$

Notice that it is also possible to eliminate the seed variable altogether by first rewriting equation (13b) as

$$S_n^1 = \sigma\gamma p_{n-1} \tag{14}$$

and then substituting it into equation (13a) to get

$$p_{n+1} = \alpha\sigma\gamma p_n + \beta\sigma^2(1 - \alpha)\gamma p_{n-1}. \tag{15}$$

We observe that the model can be formulated in a number of alternative ways, as a system of two first-order equations or as one second-order equation (15). Equation (15) is linear since no multiples $p_n p_m$ or terms that are nonlinear in p_n occur; it is second order since two previous generations are implicated in determining the present generation.

Notice that the system of equations (13a and b) could also have been written as a single equation for seeds.

Stage 5: Check

To be on the safe side, we shall further explore equation (15) by interpreting one of the terms on its right hand side. Rewriting it for the n th generation and reading from right to left we see that p_n is given by

$$p_n = \alpha\sigma\gamma p_{n-1} + \beta\sigma(1 - \alpha)\sigma\gamma p_{n-2}$$

and were among the fraction of two-year-old seeds that germinated

The first term is more elementary and is left as an exercise for the reader to translate.

1.3 SYSTEMS OF LINEAR DIFFERENCE EQUATIONS

The problem of annual plant reproduction leads to a system of two first-order difference equations (10,13), or equivalently a single second-order equation (15). To understand such equations, let us momentarily turn our attention to a general system of the form

$$x_{n+1} = a_{11}x_n + a_{12}y_n, \quad (16a)$$

$$y_{n+1} = a_{21}x_n + a_{22}y_n. \quad (16b)$$

As before, this can be converted to a single higher-order equation. Starting with (16a) and using (16b) to eliminate y_{n+1} , we have

$$\begin{aligned} x_{n+2} &= a_{11}x_{n+1} + a_{12}y_{n+1} \\ &= a_{11}x_{n+1} + a_{12}(a_{21}x_n + a_{22}y_n). \end{aligned}$$

From equation (16a),

$$a_{12}y_n = x_{n+1} - a_{11}x_n.$$

Now eliminating y_n we conclude that

$$x_{n+2} = a_{11}x_{n+1} + a_{12}a_{21}x_n + a_{22}(x_{n+1} - a_{11}x_n),$$

or more simply that

$$x_{n+2} - (a_{11} + a_{22})x_{n+1} + (a_{22}a_{11} - a_{12}a_{21})x_n = 0. \quad (17)$$

In a later chapter, readers may remark on the similarity to situations encountered in reducing a system of *ordinary differential equations* (ODEs) to single ODEs (see Chapter 4). We proceed to discover properties of solutions to equation (17) or equivalently, to (16a, b).

Looking back at the simple first-order linear difference equation (2), recall that solutions to it were of the form

$$x_n = C\lambda^n. \quad (18)$$

While the notation has been changed slightly, the form is still the same: constant depending on initial conditions times some number raised to the power n . Could this type of solution work for higher-order linear equations such as (17)?

We proceed to test this idea by substituting the expression $x_n = C\lambda^n$ (in the form of $x_{n+1} = C\lambda^{n+1}$ and $x_{n+2} = C\lambda^{n+2}$) into equation (17), with the result that

$$C\lambda^{n+2} - (a_{11} + a_{22})C\lambda^{n+1} + (a_{22}a_{11} - a_{12}a_{21})\lambda^n = 0.$$

Now we cancel out a common factor of $C\lambda^n$. (It may be assumed that $C\lambda^n \neq 0$ since $x_n = 0$ is a trivial solution.) We obtain

$$\lambda^2 - (a_{11} + a_{22})\lambda + (a_{22}a_{11} - a_{12}a_{21}) = 0. \quad (19)$$

Thus a solution of the form (18) would in fact work, provided that λ satisfies the quadratic equation (19), which is generally called the *characteristic equation* of (17).

To simplify notation we label the coefficients appearing in equation (19) as follows:

$$\begin{aligned}\beta &= a_{11} + a_{22}, \\ \gamma &= a_{22}a_{11} - a_{12}a_{21}.\end{aligned}\tag{20}$$

The solutions to the characteristic equation (there are two of them) are then:

$$\lambda_{1,2} = \frac{\beta \pm \sqrt{\beta^2 - 4\gamma}}{2}.\tag{21}$$

These numbers are called *eigenvalues*, and their properties will uniquely determine the behavior of solutions to equation (17). (*Note:* much of the terminology in this section is common to linear algebra; in the next section we will arrive at identical results using matrix notation.)

Equation (17) is *linear*; like all examples in this chapter it contains only scalar multiples of the variables—no quadratic, exponential, or other nonlinear expressions. For such equations, the *principle of linear superposition* holds: *if several different solutions are known, then any linear combination of these is again a solution.* Since we have just determined that λ_1^n and λ_2^n are two solutions to (17), we can conclude that a general solution is

$$x_n = A_1 \lambda_1^n + A_2 \lambda_2^n,\tag{22}$$

provided $\lambda_1 \neq \lambda_2$. (See problem 3 for a discussion of the case $\lambda_1 = \lambda_2$.) This expression involves two arbitrary scalars, A_1 and A_2 , whose values are not specified by the difference equation (17) itself. They depend on separate constraints, such as particular known values attained by x . Note that specifying any two x values uniquely determines A_1 and A_2 . Most commonly, x_0 and x_1 , the levels of a population in the first two successive generations, are given (*initial conditions*); A_1 and A_2 are determined by solving the two resulting linear algebraic equations (for an example see Section 1.7). Had we eliminated x instead of y from the system of equations (16), we would have obtained a similar result. In the next section we show that general solutions to the system of first-order linear equations (16) indeed take the form

$$\begin{aligned}x_n &= A_1 \lambda_1^n + A_2 \lambda_2^n, \\ y_n &= B_1 \lambda_1^n + B_2 \lambda_2^n.\end{aligned}\tag{23}$$

The connection between the four constants A_1 , A_2 , B_1 , and B_2 will then be made clear.

1.4 A LINEAR ALGEBRA REVIEW⁴

Results of the preceding section can be obtained more directly from equations (16a, b) using linear algebra techniques. Since these are useful in many situations, we will briefly review the basic ideas. Readers not familiar with matrix notation are encour-

4. *To the instructor:* Students unfamiliar with linear algebra and/or complex numbers can omit Sections 1.4 and 1.8 without loss of continuity. An excellent supplement for this chapter is Sherbert (1980).

aged to consult Johnson and Riess (1981), Bradley (1975), or any other elementary linear algebra text.

Recall that a shorthand way of writing the system of algebraic linear equations,

$$\begin{aligned} ax + by &= 0, \\ cx + dy &= 0, \end{aligned} \tag{24}$$

using vector notation is:

$$\mathbf{M}\mathbf{v} = 0,$$

where \mathbf{M} is a matrix of coefficients and \mathbf{v} is the vector of unknowns. Then for system (24),

$$\mathbf{M} = \begin{pmatrix} a & b \\ c & d \end{pmatrix} \quad \text{and} \quad \mathbf{v} = \begin{pmatrix} x \\ y \end{pmatrix}. \tag{25}$$

Note that $\mathbf{M}\mathbf{v}$ then represents matrix multiplication of \mathbf{M} (a 2×2 matrix) with \mathbf{v} (a 2×1 matrix).

Because (24) is a set of linear equations with zero right-hand sides, the vector $\begin{pmatrix} 0 \\ 0 \end{pmatrix}$ is always a solution. It is in fact, a *unique* solution unless the equations are “redundant.” A test for this is to see whether the determinant of \mathbf{M} is zero; i.e.,

$$\det \mathbf{M} = ad - bc = 0. \tag{26}$$

When $\det \mathbf{M} = 0$, both the equations contain the same information so that in reality, there is only one constraint governing the unknowns. That means that any combination of values of x and y will solve the problem provided they satisfy any *one* of the equations, e.g.,

$$x = -by/a.$$

Thus there are *many* nonzero solutions when (26) holds.

To apply this notion to systems of difference equations, first note that equations (16) can be written in vector notation as

$$\mathbf{V}_{n+1} = \mathbf{M}\mathbf{V}_n \tag{27a}$$

where

$$\mathbf{V}_n = \begin{pmatrix} x_n \\ y_n \end{pmatrix} \tag{27b}$$

and

$$\mathbf{M} = \begin{pmatrix} a_{11} & a_{12} \\ a_{21} & a_{22} \end{pmatrix}. \tag{27c}$$

It has already been remarked that solutions to this system are of the form

$$\mathbf{V}_n = \begin{pmatrix} A\lambda^n \\ B\lambda^n \end{pmatrix}. \tag{28a}$$

Substituting (28a) into (27a) we obtain

$$\begin{pmatrix} A\lambda^{n+1} \\ B\lambda^{n+1} \end{pmatrix} = \begin{pmatrix} a_{11} & a_{12} \\ a_{21} & a_{22} \end{pmatrix} \begin{pmatrix} A\lambda^n \\ B\lambda^n \end{pmatrix}. \tag{28b}$$

We expand the RHS to get

$$\begin{aligned} A\lambda^{n+1} &= a_{11}A\lambda^n + a_{12}B\lambda^n, \\ B\lambda^{n+1} &= a_{21}A\lambda^n + a_{22}B\lambda^n. \end{aligned} \tag{28c}$$

We then cancel a factor of λ^n and rearrange terms to arrive at the following system of equations:

$$\begin{aligned} 0 &= A(a_{11} - \lambda) + Ba_{12}, \\ 0 &= A(a_{21}) + B(a_{22} - \lambda). \end{aligned} \tag{29}$$

This is equivalent to

$$0 = \begin{pmatrix} a_{11} - \lambda & a_{12} \\ a_{21} & a_{22} - \lambda \end{pmatrix} \begin{pmatrix} A \\ B \end{pmatrix}.$$

These are now linear algebraic equations in the quantities A and B . One solution is always $A = B = 0$, but this is clearly a trivial one because it leads to

$$\mathbf{V} = 0,$$

a continually zero level of both x_n and y_n . To have nonzero solutions for A and B we must set the determinant of the matrix of coefficients equal to zero;

$$\det \begin{pmatrix} a_{11} - \lambda & a_{12} \\ a_{21} & a_{22} - \lambda \end{pmatrix} = 0. \tag{30}$$

This leads to

$$(a_{11} - \lambda)(a_{22} - \lambda) - a_{12}a_{21} = 0, \tag{31}$$

which results, as before, in the quadratic characteristic equation for the eigenvalues λ . Rearranging equation (31) we obtain

$$\lambda^2 - \beta\lambda + \gamma = 0$$

where

$$\begin{aligned} \beta &= a_{11} + a_{22}, \\ \gamma &= (a_{11}a_{22} - a_{12}a_{21}). \end{aligned}$$

As before, we find that

$$\lambda_{1,2} = \frac{\beta \pm \sqrt{\beta^2 - 4\gamma}}{2}$$

are the two eigenvalues. The quantities β , γ , and $\beta^2 - 4\gamma$ have the following names and symbols:

$$\begin{aligned} \beta &= a_{11} + a_{22} = \text{Tr } \mathbf{M} = \text{the trace of the matrix } \mathbf{M} \\ \gamma &= a_{11}a_{22} - a_{12}a_{21} = \det \mathbf{M} = \text{the determinant of } \mathbf{M} \\ \beta^2 - 4\gamma &= \text{disc}(\mathbf{M}) = \text{the discriminant of } \mathbf{M}. \end{aligned}$$

If $\text{disc } \mathbf{M} < 0$, we observe that the eigenvalues are complex (see Section 1.8); if $\text{disc } \mathbf{M} = 0$, the eigenvalues are equal.

Corresponding to each eigenvalue is a nonzero vector $\mathbf{v}_i = \begin{pmatrix} A_i \\ B_i \end{pmatrix}$, called an *eigenvector*, that satisfies

$$\mathbf{M}\mathbf{v}_i = \lambda_i \mathbf{v}_i$$

This matrix equation is merely a simplified matrix version of (28c) obtained by cancelling a factor of λ^n and then applying the result to a specific eigenvalue λ_i . Alternatively the system of equations (29) in matrix form is

$$\begin{pmatrix} a_{11} - \lambda_i & a_{12} \\ a_{21} & a_{22} - \lambda_i \end{pmatrix} \begin{pmatrix} A_i \\ B_i \end{pmatrix} = 0.$$

It may be shown (see problem 4) that provided $a_{12} \neq 0$,

$$\mathbf{v}_i = \begin{pmatrix} A_i \\ B_i \end{pmatrix} = \begin{pmatrix} 1 \\ \frac{\lambda_i - a_{11}}{a_{12}} \end{pmatrix}$$

is an eigenvector corresponding to λ_i . Furthermore, any scalar multiple of an eigenvector is an eigenvector; i.e., if \mathbf{v} is an eigenvector, then so is $\alpha \mathbf{v}$ for any scalar α .

1.5 WILL PLANTS BE SUCCESSFUL?

With the methods of Sections 1.3 and 1.4 at our disposal let us return to the topic of annual plant propagation and pursue the investigation of behavior of solutions to equation (15). The central question that the model should resolve is how many seeds a given plant should produce in order to ensure survival of the species. We shall explore this question in the following series of steps.

To simplify notation, let $a = \alpha\sigma\gamma$ and $b = \beta\sigma^2(1 - \alpha)\gamma$. Then equation (15) becomes

$$p_{n+1} - ap_n - bp_{n-1} = 0, \quad (32)$$

with corresponding characteristic equation

$$\lambda^2 - a\lambda - b = 0. \quad (33)$$

Eigenvalues are

$$\begin{aligned} \lambda_{1,2} &= \frac{1}{2}(a \pm \sqrt{a^2 + 4b}) \\ &= \frac{\sigma\gamma\alpha}{2}(1 \pm \sqrt{1 + \delta}), \end{aligned} \quad (34)$$

where

$$\delta = \frac{4\beta(1 - \alpha)}{\gamma\alpha^2} = \frac{4\beta}{\gamma\alpha} \left(\frac{1}{\alpha} - 1 \right)$$

is a positive quantity since $\alpha < 1$.

We have arrived at a rather cumbersome expression for the eigenvalues. The following rough approximation will give us an estimate of their magnitudes.

Initially we consider a special case. Suppose few two-year-old seeds germinate in comparison with the one-year-old seeds. Then β/α is very small, making δ small relative to 1. This means that at the very least, the positive eigenvalue λ_1 has magnitude

$$\lambda_1 \approx \frac{\sigma\gamma\alpha}{2}(1 + \sqrt{1}) = 2 \frac{\sigma\gamma\alpha}{2} = \sigma\gamma\alpha.$$

Thus, to ensure propagation we need the following conditions:

$$\lambda_1 > 1, \quad \sigma\gamma\alpha > 1, \quad \gamma > 1/\sigma\alpha. \quad (35a)$$

By this reasoning we may conclude that the population will grow if the number of seeds per plant is greater than $1/\sigma\alpha$. To give some biological meaning to equation (35a), we observe that the quantity $\sigma\gamma\alpha$ represents the number of seeds produced by a given plant that actually survive and germinate the following year. The approximation $\beta \approx 0$ means that the parent plant can only be assured of replacing itself if it gives rise to at least *one* such germinated seed. Equation (35a) gives a “strong condition” for plant success where dormancy is not playing a role. If β is not negligibly small, there will be a finite probability of having progeny in the second year, and thus the condition for growth of the population will be less stringent. It can be shown (see problem 17e) that in general $\lambda_1 > 1$ if

$$\gamma > \frac{1}{\alpha\sigma + \beta\sigma^2(1 - \alpha)}. \quad (35b)$$

When $\beta = 0$ this condition reduces to that of (35a). We postpone the discussion of this case to problem 12 of Chapter 2.

As a final step in exploring the plant propagation problem, a simple computer program was written in BASIC and run on an IBM personal computer. The two sample runs derived from this program (see Table 1.1) follow the population for 20 generations starting with 100 plants and no seeds. In the first case $\alpha = 0.5$, $\gamma = 0.2$, $\sigma = 0.8$, $\beta = 0.25$, and the population dwindles. In the second case α and β have been changed to $\alpha = 0.6$, $\beta = 0.3$, and the number of plants is seen to increase from year to year. The general condition (35b) is illustrated by the computer simulations since, upon calculating values of the expressions $1/\alpha\sigma$ and $1/(\alpha\sigma + \beta\sigma^2(1 - \alpha))$ we obtain (a) 2.5 and 2.32 in the first simulation and (b) 2.08 and 1.80 in the second. Since $\gamma = 2.0$ in both cases, we observe that dormancy played an essential role in plant success in simulation b.

To place this linear model in proper context, we should add various qualifying remarks. Clearly we have made many simplifying assumptions. Among them, we have assumed that plants do not interfere with each other's success, that germination and survival rates are constant over many generations, and that all members of the plant population are identical. The problem of seed dispersal and dormancy has been examined by several investigators. For more realistic models in which other factors such as density dependence, environmental variability, and nonuniform distributions of plants are considered, the reader may wish to consult Levin, Cohen, and Hastings

Table 1.1 Changes in a Plant Population over 20 Generations: (a) $\alpha = 0.5$, $\beta = 0.25$, $\gamma = 2.0$, $\sigma = 0.8$; (b) $\alpha = 0.6$, $\beta = 0.3$, $\gamma = 2.0$, $\sigma = 0.8$

<i>Generation</i>	<i>Plants</i>	<i>New seeds</i>	<i>One-year-old seeds</i>	<i>Two-year old seeds</i>
0	100.0	0.0	0.0	0.0
1	80.0	200.0	160.0	0.0
2	80.0	160.0	128.0	64.0
3	76.8	160.0	128.0	51.2
4	74.2	153.6	122.8	51.2
5	71.6	148.4	118.7	49.1
6	69.2	143.3	114.6	47.5
7	66.8	138.4	110.7	45.8
8	64.5	133.6	106.9	44.3
9	62.3	129.1	103.2	42.7
10	60.1	124.6	99.7	41.3
11	58.1	120.3	96.3	39.8
12	56.1	116.2	93.0	38.5
13	54.2	112.2	89.8	37.2
14	52.3	108.4	86.7	35.9
15	50.5	104.7	83.7	34.6
16	48.8	101.1	80.8	33.5
17	47.1	97.6	78.1	32.3
18	45.5	94.2	75.4	31.2
19	43.9	91.0	72.8	30.1
20	42.4	87.9	70.3	29.1

<i>Generation</i>	<i>Plants</i>	<i>New seeds</i>	<i>One-year-old seeds</i>	<i>Two-year-old seeds</i>
0	100.0	0.0	0.0	0.0
1	96.0	200.0	160.0	0.0
2	107.5	192.0	153.6	51.2
3	117.9	215.0	172.0	49.1
4	129.7	235.9	188.7	55.0
5	142.6	259.5	207.6	60.3
6	156.9	285.3	228.3	66.4
7	172.5	313.8	251.0	73.0
8	189.7	345.1	276.0	80.3
9	208.6	379.5	303.6	88.3
10	229.4	417.3	333.8	97.1
11	252.3	458.9	367.1	106.8
12	277.4	504.6	403.7	117.4
13	305.1	554.9	443.9	129.1
14	335.5	610.3	488.2	142.0
15	369.0	671.1	536.9	156.2
16	405.8	738.0	590.4	171.8
17	446.2	811.6	649.2	188.9
18	490.7	892.5	714.0	207.7
19	539.6	981.4	785.1	228.4
20	593.4	1079.2	863.4	251.2

(1984) and references therein. A related problem involving resistance to herbicides is treated by Segel (1981).

Recent work by Ellner (1986) is relevant to the basic issue of delayed germination in annual plants. Apparently, there is some debate over the underlying biological advantage gained by prolonging the opportunities for germination. Germination is usually controlled exclusively by the *seed coat*, whose properties derive genetically from the mother plant. Mechanical or chemical factors in the seed coat may cause a delay in germination. As a result some of the seeds may not be able to take advantage of conditions that favor seedling survival. In this way the mother plant can maintain some influence on its progeny long after their physical separation. It is held that spreading germination over a prolonged time period may help the mother plant to minimize the risk of losing all its seeds to chance mortality due to environmental conditions. From the point of view of the offspring, however, maternal control may at times be detrimental to individual survival. This *parent-offspring conflict* occurs in a variety of biological settings and is of recent popularity in several theoretical treatments. See Ellner (1986) for a discussion.

1.6 QUALITATIVE BEHAVIOR OF SOLUTIONS TO LINEAR DIFFERENCE EQUATIONS

To recapitulate the results of several examples, linear difference equations are characterized by the following properties:

1. An m th-order equation typically takes the form

$$a_0x_n + a_1x_{n-1} + \cdots + a_mx_{n-m} = b_n,$$

or equivalently,

$$a_0x_{n+m} + a_1x_{n+m-1} + \cdots + a_mx_n = b_n.$$

2. The *order* m of the equation is the number of previous generations that directly influence the value of x in a given generation.
3. When a_0, a_1, \dots, a_m are constants and $b_n = 0$, the problem is a *constant-coefficient homogeneous linear difference equation*; the method established in this chapter can be used to solve such equations. Solutions are composed of linear combinations of basic expressions of the form

$$x_n = C\lambda^n. \quad (36)$$

4. Values of λ appearing in equation (36) are obtained by finding the roots of the corresponding characteristic equation

$$a_0\lambda^m + a_1\lambda^{m-1} + \cdots + a_m = 0.$$

5. The number of (distinct) basic solutions to a difference equation is determined by its order. For example, a first-order equation has one solution, and a second-order equation has two. In general, an m th-order equation, like a system of m coupled first-order equations, has m basic solutions.

6. The general solution is a linear superposition of the m basic solutions of the equation (provided all values of λ are distinct).
7. For real values of λ the qualitative behavior of a basic solution (24) depends on whether λ falls into one of four possible ranges:

$$\lambda \geq 1, \quad \lambda \leq -1, \quad 0 < \lambda < 1, \quad -1 < \lambda < 0.$$

To observe how the nature of a basic solution is characterized by this broad classification scheme, note that

- (a) For $\lambda > 1$, λ^n grows as n increases; thus $x_n = C\lambda^n$ grows without bound.
- (b) For $0 < \lambda < 1$, λ^n decreases to zero with increasing n ; thus x_n decreases to zero.
- (c) For $-1 < \lambda < 0$, λ^n oscillates between positive and negative values while declining in magnitude to zero.
- (d) For $\lambda < -1$, λ^n oscillates as in (c) but with increasing magnitude.

The cases where $\lambda = 1$, $\lambda = 0$, or $\lambda = -1$, which are marginal points of demarcation between realms of behavior, correspond respectively to (1) the static (nongrowing) solution where $x = C$, (2) $x = 0$, and (3) an oscillation between the value $x = C$ and $x = -C$. Several representative examples are given in Figure 1.3.

Linear difference equations for which $m > 1$ have general solutions that combine these broad characteristics. However, note that linear combinations of expressions of the form (36) show somewhat more subtle behavior. The *dominant eigenvalue* (the value λ_i of largest magnitude) has the strongest effect on the solution; this means that after many generations the successive values of x are approximately related by

$$x_{n+1} \approx \lambda_i x_n.$$

Clearly, whether the general solution increases or decreases in the long run depends on whether any one of its eigenvalues satisfies the condition

$$|\lambda_i| > 1.$$

If so, net growth occurs. The growth equation contains an oscillatory component if one of the eigenvalues is negative or complex (to be discussed). However, any model used to describe population growth cannot admit negative values of x_n . Thus, while oscillations typically may occur, they are generally superimposed on a larger-amplitude behavior so that successive x_n levels remain positive.

In difference equations for which $m \geq 2$, the values of λ from which basic solutions are composed are obtained by extracting roots of an m th-order polynomial. For example, a second-order difference equation leads to a quadratic characteristic equation. Such equations in general may have complex roots as well as repeated roots. Thus far we have deliberately ignored these cases for the sake of simplicity. We shall deal with the case of complex (and not real) λ in Section 1.8 and touch on the case of repeated real roots in the problems.

Figure 1.3 Qualitative behavior of $x_n = C\lambda^n$ in the four cases (a) $\lambda > 1$, (b) $0 < \lambda < 1$, (c) $-1 < \lambda < 0$, (d) $\lambda < -1$.

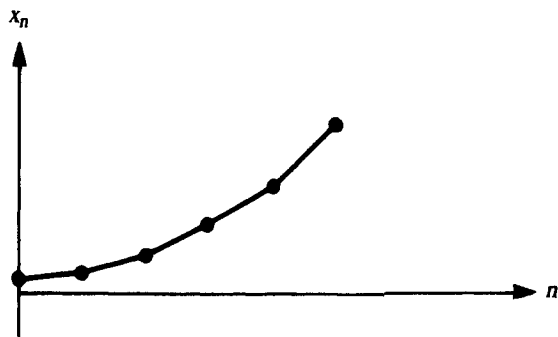

(a)

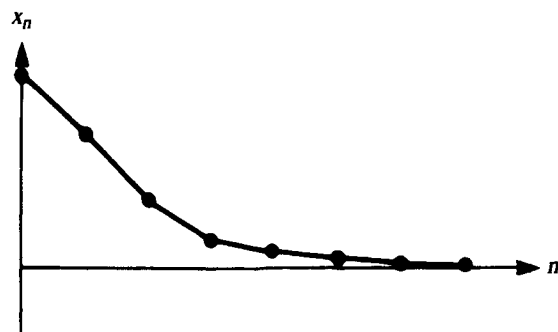

(b)

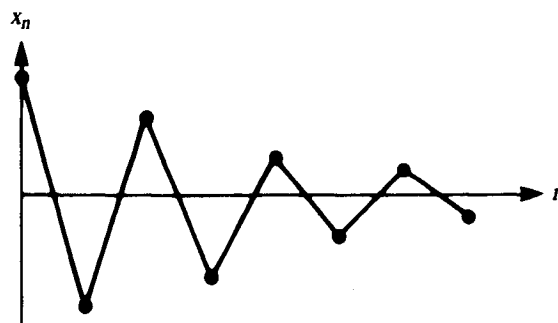

(c)



(d)

1.7 THE GOLDEN MEAN REVISITED

We shall apply techniques of this chapter to equation (1), which stems from Fibonacci's work. Assuming solutions of the form (18), we arrive at a characteristic equation corresponding to (1):

$$\lambda^2 = \lambda + 1.$$

Roots are

$$\lambda_1 = (1 - \sqrt{5})/2 \quad \text{and} \quad \lambda_2 = (1 + \sqrt{5})/2.$$

Successive members of the Fibonacci sequence are thus given by the formula

$$x_n = A\lambda_1^n + B\lambda_2^n.$$

Suppose we start the sequence with $x_0 = 0$ and $x_1 = 1$. This will uniquely determine the values of the two constants A and B , which must satisfy the following algebraic equations:

$$\begin{aligned} 0 &= A\lambda_1^0 + B\lambda_2^0 = A + B, \\ 1 &= A\lambda_1 + B\lambda_2 = \frac{1}{2}[A(1 - \sqrt{5}) + B(1 + \sqrt{5})]. \end{aligned}$$

It may be shown that A and B are given by

$$A = -1/\sqrt{5} \quad \text{and} \quad B = +1/\sqrt{5}.$$

Thus the solution is

$$x_n = -\frac{1}{\sqrt{5}} \left(\frac{1 - \sqrt{5}}{2} \right)^n + \frac{1}{\sqrt{5}} \left(\frac{1 + \sqrt{5}}{2} \right)^n.$$

Observe that $\lambda_2 > 1$ and $-1 < \lambda_1 < 0$. Thus the dominant eigenvalue is $\lambda_2 = (1 + \sqrt{5})/2$, and its magnitude guarantees that the Fibonacci numbers form an increasing sequence. Since the second eigenvalue is negative but of magnitude smaller than 1, its only effect is to superimpose a slight oscillation that dies out as n increases. It can be concluded that for large values of n the effect of λ_1 is negligible, so that

$$x_n \approx (1/\sqrt{5})\lambda_2^n.$$

The ratios of successive Fibonacci numbers converge to

$$\frac{x_{n+1}}{x_n} = \lambda_2 = \frac{1 + \sqrt{5}}{2}.$$

Thus the value of the golden mean is $(1 + \sqrt{5})/2 = 1.618033 \dots$

1.8 COMPLEX EIGENVALUES IN SOLUTIONS TO DIFFERENCE EQUATIONS

The quadratic characteristic equation (19) can have complex eigenvalues (21) with nonzero imaginary parts when $\beta^2 < 4\gamma$. These occur in conjugate pairs,

$$\lambda_1 = a + bi \quad \text{and} \quad \lambda_2 = a - bi,$$

where $a = \beta/2$ and $b = \frac{1}{2}|\beta^2 - 4\gamma|^{1/2}$. A similar situation can occur in linear difference equations of any order greater than 1, since these are associated with polynomial characteristic equations.

When complex values of λ are obtained, it is necessary to make sense of general solutions that involve powers of complex numbers. For example,

$$x_n = A_1(a + bi)^n + A_2(a - bi)^n. \quad (37)$$

To do so, we must first review several fundamental properties of complex numbers.

Review of Complex Numbers

A complex number can be represented in two equivalent ways. We may take $a + bi$ to be a point in the complex plane with coordinates (a, b) . Equivalently, by specifying an angle ϕ in *standard position* (clockwise from positive real axis to $a + bi$) and a distance, r from (a, b) to the origin, we can represent the complex number by a pair (r, ϕ) . These coordinates can be related by

$$a = r \cos \phi, \quad (38a)$$

$$b = r \sin \phi. \quad (38b)$$

Equivalently

$$r = (a^2 + b^2)^{1/2}, \quad (39a)$$

$$\phi = \arctan (b/a). \quad (39b)$$

The following identities, together known as *Euler's theorem*, summarize these relations; they can also be considered to define $e^{i\phi}$:

$$a + bi = r(\cos \phi + i \sin \phi) = re^{i\phi}, \quad (40a)$$

$$a - bi = r(\cos \phi - i \sin \phi) = re^{-i\phi}. \quad (40b)$$

This leads to the conclusion that raising a complex number to some power can be understood in the following way:

$$(a + bi)^n = (re^{i\phi})^n = r^n e^{in\phi} = c + di,$$

where

$$c = r^n \cos n\phi, \quad (41a)$$

$$d = r^n \sin n\phi. \quad (41b)$$

Graphically the relationship between the complex numbers $a + bi$ and $c + di$ is as follows: the latter has been obtained by rotating the vector (a, b) by a multiple n of the angle ϕ and then extending its length to a power n of its former length. (See Figure 1.4.) This rotating vector will lead to an oscillating solution, as will be clarified shortly.

Proceeding formally, we rewrite (37) using equations (40a,b):

$$\begin{aligned} x_n &= A_1(a + bi)^n + A_2(a - bi)^n \\ &= A_1 r^n (\cos n\phi + i \sin n\phi) + A_2 r^n (\cos n\phi - i \sin n\phi) \\ &= B_1 r^n \cos n\phi + i B_2 r^n \sin n\phi, \end{aligned}$$

Figure 1.4 (a) Representation of a complex number as a point in the complex plane in both cartesian (a, b) and polar (r, ϕ) coordinates. (b) A succession of values of the complex numbers $(1 + i)^n$. The radius vector rotates and stretches as higher powers are taken.

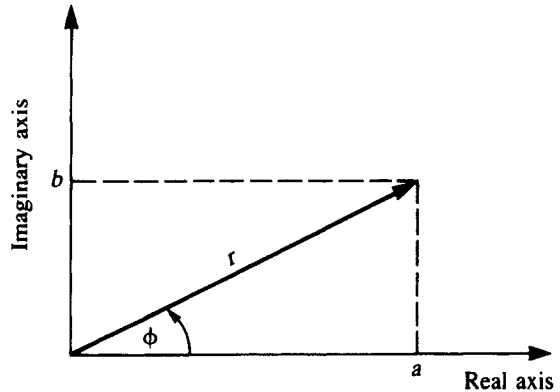

(a)

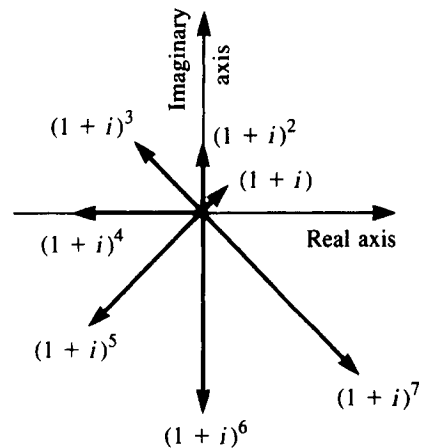

(b)

where $B_1 = A_1 + A_2$ and $B_2 = (A_1 - A_2)$. Thus x_n has a real part and an imaginary part. For

$$u_n = r^n \cos n\phi, \quad (42a)$$

$$v_n = r^n \sin n\phi, \quad (42b)$$

we have

$$x_n = B_1 u_n + iB_2 v_n. \quad (43)$$

Because the equation leading to (43) is linear, it can be proved that the real and imaginary parts of this complex solution are themselves solutions. It is then customary to define a *real-valued solution* by linear superposition of the real quantities u_n and v_n :

$$\begin{aligned} x_n &= C_1 u_n + C_2 v_n \\ &= r^n (C_1 \cos n\phi + C_2 \sin n\phi) \end{aligned} \quad (44)$$

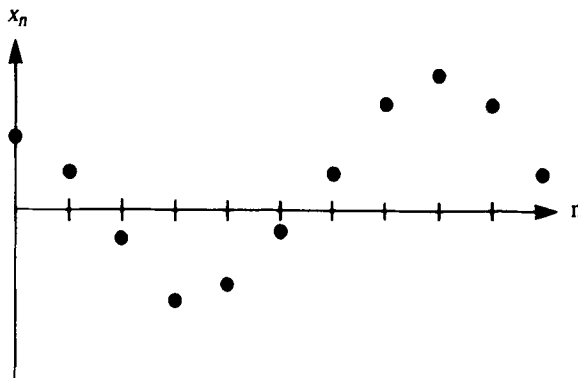

Figure 1.5 A “time sequence” of the real-valued solution given by equation (44) would display oscillations as above. Shown are values of x_n for $n = 0, 1, \dots, 10$. The amplitude of oscillation is r^n , and the frequency is $1/\phi$ where r and ϕ are given in equation (39).

where r and ϕ are related to a and b by equations (38a,b) or (39a,b). (See Figure 1.5.)

Example

The difference equation

$$x_{n+2} - 2x_{n+1} + 2x_n = 0 \tag{45}$$

has a characteristic equation

$$\lambda^2 - 2\lambda + 2 = 0,$$

with the complex conjugate roots $\lambda = 1 \pm i$. Thus $a = 1$ and $b = 1$, so that

$$r = (a^2 + b^2)^{1/2} = \sqrt{2},$$

$$\phi = \arctan(b/a) = \pi/4.$$

Thus the real-valued general solution to equation (45) is

$$x_n = \sqrt{2}^n [C_1 \cos(n\pi/4) + C_2 \sin(n\pi/4)]. \tag{46}$$

We conclude that complex eigenvalues $\lambda = a \pm bi$ are associated with oscillatory solutions. These solutions have growing or decreasing amplitudes if $r = \sqrt{a^2 + b^2} > 1$ and $r = \sqrt{a^2 + b^2} < 1$ respectively and constant amplitudes if $r = 1$. The frequency of oscillation depends on the ratio b/a . We note also that when (and only when) $\arctan(b/a)$ is a rational multiple of π and $r = 1$, the solution will be truly periodic in that it swings through a finite number of values and returns to these exact values at every cycle.

1.9 RELATED APPLICATIONS TO SIMILAR PROBLEMS

In this section we mention several problems that can be treated similarly but leave detailed calculations for independent work in the problems.

Problem 1: Growth of Segmental Organisms

The following hypothetical situation arises in organisms such as certain filamentous algae and fungi that propagate by addition of segments. The rates of growth and branching may be complicated functions of densities, nutrient availability, and internal reserves. However, we present here a simplified version of this phenomenon to illustrate the versatility of difference equation models.

A segmental organism grows by adding new segments at intervals of 24 h in several possible ways (see Figure 1.6):

1. A terminal segment can produce a single daughter with frequency p , thereby elongating its branch.
2. A terminal segment can produce a pair of daughters (dichotomous branching) with frequency q .
3. A next-to-terminal segment can produce a single daughter (lateral branching) with frequency r .

The question to be addressed is how the numbers of segments change as this organism grows.

In approaching the problem, it is best to define the variables depicting the number of segments of each type (terminal and next-to-terminal), to make several

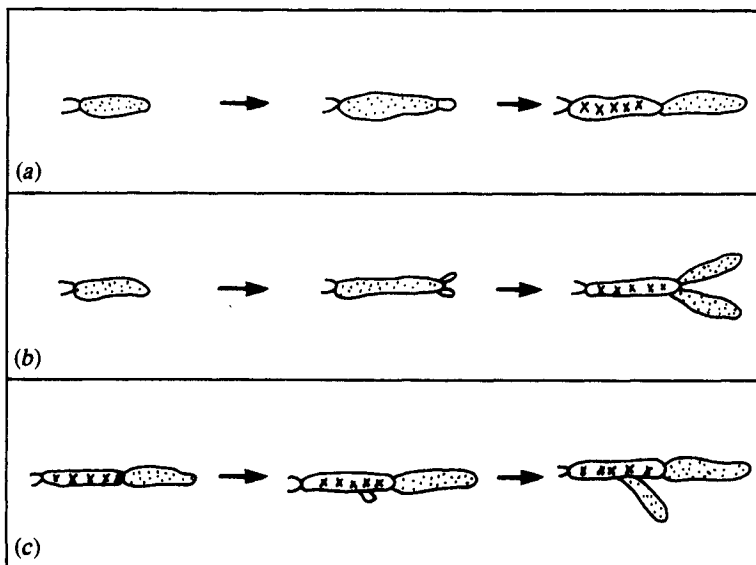

Figure 1.6 A hypothetical segmental organism can grow in one of three ways: (a) by addition of a new segment at its terminal end; by (b) dichotomous branching, in which two new segments are added at the apex; and by (c) lateral branching, which

occurs at a next-to-terminal segment. Terminal segments are dotted, and next-to-terminal segments are marked with x 's. Problem 1 proposes a modeling problem based on branching growth.

assumptions, and to account for each variable in a separate equation. The equations can then be combined into a single higher-order equation by means analogous to those given in Section 1.2. Problem 15 gives a guided approach.

For a more advanced model of branching that deals with transport of vesicles within the filaments, see Prosser and Trinci (1979).

Problem 2: A Schematic Model of Red Blood Cell Production

The following problem⁵ deals with the number of red blood cells (RBCs) circulating in the blood. Here we will present it as a discrete problem to be modeled by difference equations, though a different approach is clearly possible.

In the circulatory system, the red blood cells (RBCs) are constantly being destroyed and replaced. Since these cells carry oxygen throughout the body, their number must be maintained at some fixed level. Assume that the spleen filters out and destroys a certain fraction of the cells daily and that the bone marrow produces a number proportional to the number lost on the previous day. What would be the cell count on the n th day?

To approach this problem, consider defining the following quantities:

R_n = number of RBCs in circulation on day n ,

M_n = number of RBCs produced by marrow on day n ,

f = fraction RBCs removed by spleen,

γ = production constant (number produced per number lost).

It follows that equations for R_n and M_n are

$$\begin{aligned} R_{n+1} &= (1 - f)R_n + M_n, \\ M_{n+1} &= \gamma f R_n. \end{aligned} \tag{47}$$

Problem 16 discusses this model. By solving the equations it can be shown that the only way to maintain a nearly constant cell count is to assume that $\gamma = 1$. Moreover, it transpires that the delayed response of the marrow leads to some fluctuations in the red cell population.

As in problem 2, we apply a discrete approach to a physiological situation in which a somewhat more accurate description might be that of an underlying continuous process with a time delay. (Aside from practice at formulating the equations of a discrete model, this will provide a further example of difference equations analysis.)

Problem 3: Ventilation Volume and Blood CO₂ Levels

In the blood there is a steady production of CO₂ that results from the basal metabolic rate. CO₂ is lost by way of the lungs at a ventilation rate governed by CO₂-sensitive chemoreceptors located in the brainstem. In reality, both the rate of breathing and

5. I would like to acknowledge Saleet Jafri for proposing this problem.

the depth of breathing (volume of a breath) are controlled physiologically. We will simplify the problem by assuming that breathing takes place at constant intervals $t, t + \tau, t + 2\tau, \dots$ and that the volume $V_n = V(t + n\tau)$ is controlled by the CO_2 concentration in the blood in the previous time interval, $C_{n-1} = C[t + (n - 1)\tau]$.

Keeping track of the two variables C_n and V_n might lead to the following equations:

$$C_{n+1} = \left(\begin{array}{c} \text{amount of CO}_2 \\ \text{previously in} \\ \text{blood} \end{array} \right) - (\text{amount lost}) + \left(\begin{array}{c} \text{constant production} \\ \text{due to metabolism} \end{array} \right),$$

$$V_{n+1} = \text{volume determined by CO}_2 \text{ at time } n. \quad (48)$$

We shall fill in these terms, thereby defining the quantities \mathcal{L} (amount CO_2 lost), \mathcal{S} (sensitivity to blood CO_2), and m (constant production rate of CO_2 in blood), as follows:

$$\begin{aligned} C_{n+1} &= C_n - \mathcal{L}(V_n, C_n) + m, \\ V_{n+1} &= \mathcal{S}(C_n). \end{aligned} \quad (49)$$

Before turning to the approach suggested in problem 18, it is a challenge to think about possible forms for the unspecified terms and how the resulting equations might be solved. A question to be addressed is whether the model predicts a *steady* ventilation rate (given a constant rate of metabolism) or whether certain parameter regimes might lead to fluctuations in the basal ventilation rate. This problem is closely related to one studied by Mackey and Glass (1977) and Glass and Mackey (1978), who used a differential-delay equation instead of a difference equation. The topic is thus suitable for a longer project that might include in-class presentation of their results and a comparison with the simpler model presented here. (See also review by May (1978) and Section 2.10.)

1.10 FOR FURTHER STUDY: LINEAR DIFFERENCE EQUATIONS IN DEMOGRAPHY

Demography is the study of age-structured populations. Factors such as death and birth rates correlate closely with age; such parameters also govern the way a population evolves over generations. Thus, if one is able to accurately estimate the age-dependent fecundity and mortality in a population, it is in principle possible to deduce the age structure of all successive generations. Such estimates have been available since the mid 1600s, when John Graunt used the London Bills of Mortality, an account of yearly deaths and their causes compiled in the 1600s, to infer mortality rates [see reprint of Graunt (1662) in Smith and Keyfitz (1977), and Newman (1956)]. Later, in 1693, Edmund Halley produced somewhat better estimates for the population of Breslaw, for which more complete data were available.

The mathematics of demography developed gradually over several centuries with contributions by Léonard Euler, 1760; Joshua Milne, 1815; Benjamin Gompertz, 1825; Alfred Lotka, 1907; H. Bernardelli, 1941; E. G. Lewis, 1942 and P. H.

Leslie (1945). See Smith and Keyfitz (1977) for a historical anthology. Bernardelli and Lewis were among the first to apply matrix algebra to the problem. They dealt with age structure in a population with nonoverlapping generations that can thus be modeled by a set of difference equations, one for each age class. Later Leslie formalized the theory; it is after him that Leslie matrices, which govern the succession of generations, are named.

This topic is an excellent extension of methods discussed in this chapter and is thus suitable for independent study (especially by students who have a good background in linear algebra and polynomials). See Rorres and Anton (1977) for a good introduction. Other students less conversant with the mathematics might wish to focus on the topic from a historical perspective. Smith and Keyfitz (1977) gives an excellent historical account. Several examples are given as problems at the end of this chapter and a bibliography is suggested.

PROBLEMS*

1. Consider the difference equation $x_{n+2} - 3x_{n+1} + 2x_n = 0$.
 - (a) Show that the general solution to this equation is

$$x_n = A_1 + 2^n A_2.$$

Now suppose that $x_0 = 10$ and $x_1 = 20$. Then A_1 and A_2 must satisfy the system of equations

$$A_1 + 2^0 A_2 = x_0 = 10,$$

$$A_1 + 2^1 A_2 = x_1 = 20.$$

- (b) Solve for A_1 and A_2 and find the solution to the above *initial value problem*.
2. Solve the following difference equations subject to the specified x values and sketch the solutions:
 - (a) $x_n - 5x_{n-1} + 6x_{n-2} = 0$; $x_0 = 2, x_1 = 5$.
 - (b) $x_{n+1} - 5x_n + 4x_{n-1} = 0$; $x_1 = 9, x_2 = 33$.
 - (c) $x_n - x_{n-2} = 0$; $x_1 = 3, x_2 = 5$.
 - (d) $x_{n+2} - 2x_{n+1} = 0$; $x_0 = 10$.
 - (e) $x_{n+2} + x_{n+1} - 2x_n = 0$; $x_0 = 6, x_1 = 3$.
 - (f) $x_{n+1} = 3x_n$; $x_1 = 12$.
3. *(a) In Section 1.3 it was shown that the general solution to equations (16a,b) is (22) provided $\lambda_1 \neq \lambda_2$. Show that if $\lambda_1 = \lambda_2 = \lambda$ then the general solution is

$$A_1 \lambda^n + A_2 n \lambda^n.$$

- (b) Solve and graph the solutions to each of the following equations or systems
 - (i) $x_{n+2} - x_n = 0$,

Problems preceded by asterisks () are especially challenging.

Downloaded 05/31/21 to 128.6.45.205. Redistribution subject to SIAM license or copyright; see https://pubs.siam.org/page/terms

- (ii) $x_{n+2} - 2x_{n+1} + x_n = 0,$
- (iii) $x_{n+1} = -3x_n - 2y_n,$
 $y_{n+1} = 2x_n + y_n.$
- (iv) $x_{n+1} = 5x_n - 4y_n,$
 $y_{n+1} = x_n + y_n.$

4. In Section 1.4 we determined that there are two values λ_1 and λ_2 and two vectors $\begin{pmatrix} A_1 \\ B_1 \end{pmatrix}$ and $\begin{pmatrix} A_2 \\ B_2 \end{pmatrix}$ called *eigenvectors* that satisfy equation (29).

(a) Show that this equation can be written in matrix form as

$$\lambda \begin{pmatrix} A \\ B \end{pmatrix} = \mathbf{M} \begin{pmatrix} A \\ B \end{pmatrix}$$

where \mathbf{M} is given by equation (27c).

(b) Show that one way of expressing the eigenvectors in terms of a_{ij} and λ is:

$$\begin{pmatrix} A_i \\ B_i \end{pmatrix} = \begin{pmatrix} 1 \\ \frac{\lambda_i - a_{11}}{a_{12}} \end{pmatrix}$$

for $a_{12} \neq 0$.

(c) Show that eigenvectors are defined only up to a multiplicative constant; i.e., if \mathbf{v} is an eigenvector corresponding to the eigenvalue λ , then $\alpha \mathbf{v}$ is also an eigenvector corresponding to λ for all real numbers α .

5. The *Taylor series* expansions of the functions $\sin x$, $\cos x$, and e^x are

$$\sin x = x - \frac{x^2}{2!} + \frac{x^4}{4!} - \frac{x^6}{6!} + \frac{x^8}{8!} + \dots$$

$$\cos x = 1 - x + \frac{x^3}{3!} - \frac{x^5}{5!} + \frac{x^7}{7!} - \dots$$

$$e^x = 1 + x + \frac{x^2}{2!} + \frac{x^3}{3!} + \frac{x^4}{4!} + \dots$$

Use these identities to prove Euler's theorem (equations 40). (*Note:* More details about Taylor series are given in the appendix to Chapter 2.)

6. Convert the following systems of difference equations to single higher-order equations and find their solutions. Sketch the behavior of each solution, indicating whether it increases or decreases and whether oscillations occur.

(a) $x_{n+1} = 3x_n + 2y_n$
 $y_{n+1} = x_n + 4y_n$

(d) $x_{n+1} = x_n + y_n$
 $y_{n+1} = 2x_n$

(b) $x_{n+1} = \frac{x_n}{4} + y_n$
 $y_{n+1} = \frac{3x_n}{16} - \frac{y_n}{4}$

(e) $x_{n+1} = -x_n + 3y_n$
 $y_{n+1} = \frac{y_n}{3}$

(c) $x_{n+1} = \sigma_1 x_n + \sigma_2 y_n$
 $y_{n+1} = \beta x_n$

(f) $x_{n+1} = \frac{x_n}{4} + 3y_n$
 $y_{n+1} = -\frac{x_n}{8} + y_n$

7. For each system in problem 6 determine the eigenvalues and eigenvectors and express the solutions in vector form (see problem 4).
8. The following complex numbers are expressed as $\lambda = a + bi$, where a is the real part and b the imaginary part. Express the number in polar form $\lambda = re^{i\theta}$, and use your result to compute the indicated power λ^n of this complex number. Sketch λ^n , for $n = 0, 1, 2, 3, 4$, as a function of n .
- (a) $1 + i$ (d) $-1 + \sqrt{3}i$
 (b) $1 - i$ (e) $-\frac{1}{2} - \frac{i}{2}$
 (c) $10i$

9. *Complex eigenvalues.* Solve and graph the solutions to the following difference equations
- (a) $x_{n+2} + x_n = 0$, (c) $x_{n+2} - 2x_{n+1} + 2x_n = 0$,
 (b) $x_{n+2} - x_{n+1} + x_n = 0$, (d) $x_{n+2} + 2x_{n+1} + 3x_n = 0$.

10. (a) Consider the growth of an aphid population described in Section 1.1. If the fractional mortality of aphids is 80% and the sex ratio (ratio of females to the total number of aphids) is 50%, what minimum fecundity f is required to prevent extinction?
- (b) Establish a general condition on the fecundity of aphids to guarantee population growth given a fixed survivorship and a known sex ratio.

11. (a) Solve the first order equation $x_{n+1} = ax_n + b$ (a, b constants).
 (b) Consider the difference equation

$$aX_{n+2} + bX_{n+1} + cX_n = d.$$

If $d \neq 0$, the equation is called *nonhomogeneous*. Show that $X_n = K$, where K is a particular constant, will solve this second order nonhomogeneous equation (provided $\lambda = 1$ is not an eigenvalue) and find the value of K . (This is called a *particular solution*.)

- (c) Suppose the solution to the corresponding homogeneous equation $aX_{n+2} + bX_{n+1} + cX_n = 0$ is

$$X_n = c_1 \lambda_1^n + c_2 \lambda_2^n,$$

where c_1 and c_2 are arbitrary constants. (This is called the *complementary or homogeneous solution*.) Show that

$$X_n = K + c_1 \lambda_1^n + c_2 \lambda_2^n$$

will be a solution to the nonhomogeneous problem (provided $\lambda_1 \neq \lambda_2$ and $\lambda_i \neq 1$). This solution is called the *general solution*. *Note:* As in linear nonhomogeneous differential equations, one obtains the result that for nonhomogeneous difference equations:

general solution = complementary solutions + particular solution.

12. (a) Show that equation (1) implies that τ , the golden mean, satisfies the relation

$$1 + \frac{1}{\tau} = \tau.$$

- (b) Use this result to demonstrate that τ can be expressed as a nonterminating continued fraction, as follows:

$$\tau = 1 + \frac{1}{1 + \frac{1}{1 + \frac{1}{1 + \frac{1}{1 + \dots}}}}$$

- *13. (a) Solve equation (1) subject to the initial values $n_0 = g_0 = 2$ and $n_1 = g_1 = 1$. The sequence of numbers you will obtain was first considered by E. Lucas (1842–1891). Determine the values of $g_2, g_3, g_4, \dots, g_{10}$.
- (b) Show that in general

$$g_n = f_{n-1} + f_{n+1},$$

where f_n is the n th Fibonacci number and g_n is the n th Lucas number.

- (c) Similarly show that

$$f_{2n} = f_n g_n.$$

14. *The Rabbit problem.* In 1202 Fibonacci posed and solved the following problem. Suppose that every pair of rabbits can reproduce only twice, when they are one and two months old, and that each time they produce exactly one new pair of rabbits. Assume that all rabbits survive. Starting with a single pair in the first generation, how many pairs will there be after n generations? (See figure.)

- (a) To solve this problem, define

R_n^0 = number of newborn pairs in generation n ,

R_n^1 = number of one-month-old pairs in generation n ,

R_n^2 = number of two-month-old pairs in generation n .

Show that R_n^0 satisfies the equation

$$R_{n+1}^0 = R_n^0 + R_{n-1}^0.$$

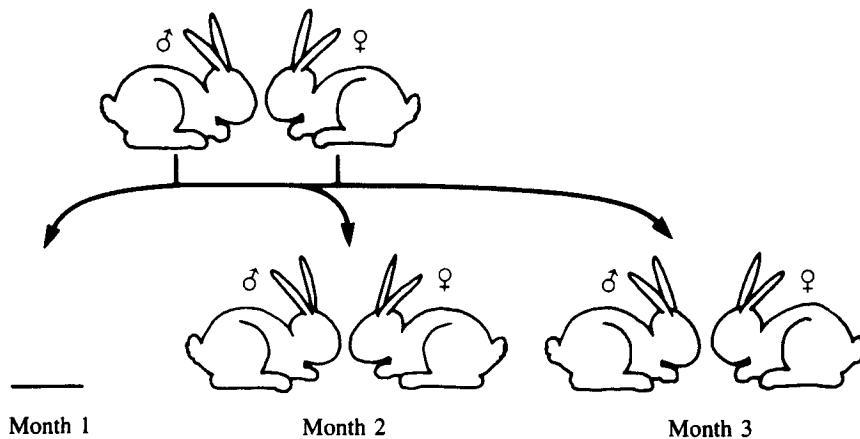

Figure for problem 14.

- (b) Suppose that Fibonacci initially had one pair of newborn rabbits, i.e., that $R_0^0 = 1$ and $R_1^0 = 1$. Find the numbers of newborn, one-month-old, and two-month-old rabbits he had after n generations.

(Historical note to problem 14: F.C. Gies quotes a different version of Fibonacci's question, reprinted from the *Liber abaci* in the 1981 edition of the *Encyclopedia Britannica*: "A certain man put a pair of rabbits in a place surrounded on all sides by a wall. How many pairs of rabbits can be produced from that pair in a year if it is supposed that every month each pair begets a new pair which from the second month on becomes productive?")

- 15. In this problem we pursue the topic of segmental growth suggested in Section 1.9.

- (a) Let a_n = number of terminal segments,
 b_n = number of next-to-terminal segments,
 s_n = total number of segments.

Assume that all daughters are terminal segments; that all terminal segments participate in growth ($p + q = 1$) and thereby become next-to-terminal segments in a single generation; and that all next-to-terminal segments are thereby displaced and can no longer branch after each generation. Write equations for these three variables.

- (b) Show that equations for a_n and b_n can be combined to give

$$a_{n+1} - (1 + q)a_n - ra_{n-1} = 0,$$

and explain the equation.

- (c) If initially there is just one terminal segment, how many terminal segments will there be after 10 days? What will be the total number of segments?

- 16. *Red blood cell production*

- (a) Explain the equations given in Section 1.9, and show that they can be reduced to a single, higher-order equation.
- (b) Show that eigenvalues are given by

$$\lambda_{1,2} = \frac{(1 - f) \pm \sqrt{(1 - f)^2 + 4\gamma f}}{2},$$

and determine their signs and magnitudes.

- (c) For homeostasis in the red cell count, the total number of red blood cells, R_n , should remain roughly constant. Show that one way of achieving this is by letting $\lambda_1 = 1$. What does this imply about γ ?
- (d) Using the results of part (c) show that the second eigenvalue is then given by $\lambda_2 = -f$. What then is the behavior of the solution

$$R_n = A\lambda_1^n + B\lambda_2^n?$$

- 17. *Annual plant propagation*

- (a) The model for annual plants was condensed into a single equation (15) for p_n , the number of plants. Show that it can also be written as a single equation in S_n^1 .
- (b) Explain the term $\alpha\sigma\gamma p_n$ in equation (15).

- (c) Let $\alpha = \beta = 0.001$ and $\sigma = 1$. How big should γ be to ensure that the plant population increases in size?
- (d) Explain why the plant population increases or decreases in the two simulations shown in Table 1.1.
- (e) Show that equation (35b) gives a more general condition for plant success. (*Hint*: Consider $\lambda_1 = \frac{1}{2}(a \pm \sqrt{a^2 + 4b})$ and show that $\lambda_1 > 1$ implies $a + b < 1$.)

18. *Blood CO₂ and ventilation.* We now consider the problem of blood CO₂ and the physiological control of ventilation.

- (a) As a first model, assume that the amount of CO₂ lost, $\mathcal{L}(V_n, C_n)$, is simply proportional to the ventilation volume V_n with constant factor β (and does not depend on C_n). Further assume that the ventilation at time $n + 1$ is directly proportional to C_n (with factor α), i.e., that $\mathcal{V}(C_n) = \alpha C_n$. (This may be physiologically unrealistic but for the moment it makes the model linear.) Write down the system of equations (49) and show that it corresponds to a single equation

$$C_{n+1} - C_n + \alpha\beta C_{n-1} = m.$$

- (b) For $m \neq 0$ the equation in part (a) is a nonhomogeneous problem. Use the steps outlined in problem (11) to solve it.
 - (1) Show that $C_n = m/\alpha\beta$ is a particular solution.
 - (2) Find the general solution.
- (c) Now consider the nature of this solution in two stages.
 - (1) First assume that $4\alpha\beta < 1$. Interpret this inequality in terms of the biological process. Give evidence for the assertion that under this condition, a steady blood CO₂ level C equal to $m/\alpha\beta$ will eventually be established, regardless of the initial conditions. What will the steady ventilation rate then be? (*Hint*: Show that $|\lambda_i| < 1$.)
 - (2) Now suppose $4\alpha\beta > 1$. Show that the CO₂ level will undergo oscillations. If $\alpha\beta$ is large enough, show that the oscillations may *increase* in magnitude. Find the frequency of the oscillations. Comment on the biological relevance of this solution. May (1978) refers to such situations as *dynamical diseases*.
- (d) Suggest how the model might be made more realistic. The equations you obtain may be nonlinear. Determine whether they admit *steady-state solutions* in which $C_{n+1} = C_n$ and $V_{n+1} = V_n$.

19. This problem demonstrates an alternate formulation for the annual plant model in which we define the beginning of a generation at the time when seeds are produced. The figure shows the new census method.

- (a) Define the variables and write new equations linking them.
- (b) Show that the system can be condensed to the following two equations,

$$S_{n+1}^0 = \gamma(\beta S_n^1 + \alpha S_n^0),$$

$$S_{n+1}^1 = \sigma(1 - \alpha)S_n^0,$$

and that in matrix form the system can be represented by

$$\begin{pmatrix} S^0 \\ S^1 \end{pmatrix}_{n+1} = \begin{pmatrix} \gamma\alpha & \gamma\beta \\ \sigma(1 - \alpha) & 0 \end{pmatrix} \begin{pmatrix} S^0 \\ S^1 \end{pmatrix}_n.$$

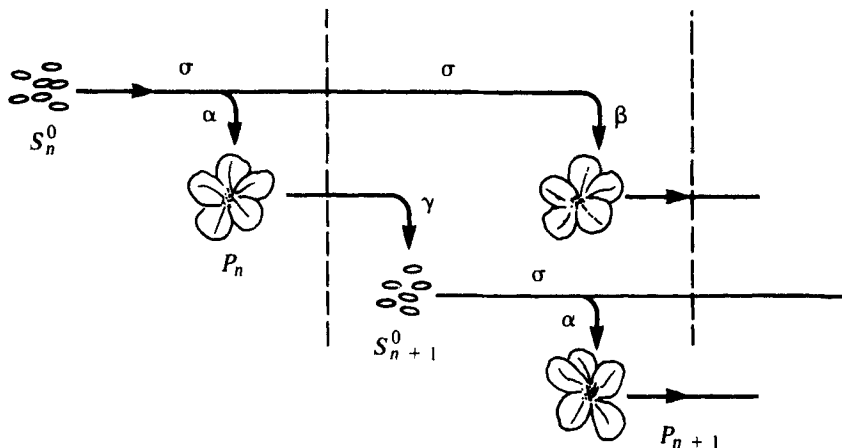

Figure for problem 19.

- (c) (i) Solve the system given in (b).
- (ii) Show that $p_{n+2} - \alpha\sigma\gamma p_{n+1} - \beta\sigma\gamma(1 - \alpha)p_n = 0$.
- (iii) Show that the adult plant population is preserved (i.e., $\lambda_1 \geq 1$) if and only if

$$\gamma \geq \frac{1}{\alpha\sigma + \beta\sigma^2(1 - \alpha)}$$

- (d) Similarly consider this problem in which now seeds S_n^0 can survive and germinate in generations $n, n + 1, n + 2$, and $n + 3$, with germination fractions α, β, δ , and ϵ . Show that the corresponding system of equations in matrix form would be

$$\begin{pmatrix} S^0 \\ S^1 \\ S^2 \\ S^3 \end{pmatrix}_{n+1} = \begin{pmatrix} \gamma\alpha & \gamma\beta & \gamma\delta & \gamma\epsilon \\ \sigma(1 - \alpha) & 0 & 0 & 0 \\ 0 & \sigma^2(1 - \alpha - \beta) & 0 & 0 \\ 0 & 0 & \sigma^3(1 - \alpha - \beta - \delta) & 0 \end{pmatrix} \begin{pmatrix} S^0 \\ S^1 \\ S^2 \\ S^3 \end{pmatrix}_n$$

Interpret the terms in this matrix. You may wish to write out explicitly the system of equations.

- 20. (a) Consider a population with m age classes, and let $p_n^1, p_n^2, \dots, p_n^m$ be the numbers of individuals within each class such that p_n^0 is the number of newborns and p_n^m is the number of oldest individuals. Define

$\alpha_1, \dots, \alpha_k, \dots, \alpha_m$ = number of births from individuals of a given age class,

$\sigma_1, \dots, \sigma_k, \dots, \sigma_{m-1}$ = fraction of k year olds that survive to be $k + 1$ year olds.

Show that the system can be described by the following matrix equation:

$$\mathbf{P}_{n+1} = \mathbf{A} \mathbf{P}_n,$$

where

$$\mathbf{P} = \begin{pmatrix} p^1 \\ p^2 \\ \vdots \\ p^m \end{pmatrix}, \quad \mathbf{A} = \begin{pmatrix} \alpha_1 & \alpha_2 & \cdots & \alpha_m \\ \sigma_1 & 0 & \cdots & 0 \\ 0 & \sigma_2 & \cdots & \\ 0 & 0 & \cdots & \sigma_{m-1} \end{pmatrix}.$$

\mathbf{A} is called a *Leslie matrix*. (See references on demography for a summary of special properties of such matrices.) *Note:* For biological realism, we assume at least one $\alpha_i > 0$ and all $\sigma_i > 0$.)

***(b)** The characteristic equation of a Leslie matrix is

$$p_n(\lambda) = \det(\lambda \mathbf{I} - \mathbf{A}) = 0.$$

Show that this leads to the equation

$$\lambda^n - \alpha_1 \lambda^{n-1} - \alpha_2 \sigma_1 \lambda^{n-2} - \alpha_3 \sigma_1 \sigma_2 \lambda^{n-3} - \cdots - \alpha_n \sigma_1 \sigma_2 \cdots \sigma_{n-1} = 0.$$

***(c)** A Leslie matrix has a unique positive eigenvalue λ^* . To prove this assertion, define the function

$$f(\lambda) = 1 - \frac{p_n(\lambda)}{\lambda^n}.$$

Show that $f(\lambda)$ is a monotone decreasing function with $f(\lambda) \rightarrow +\infty$ for $\lambda \rightarrow 0$, $f(\lambda) \rightarrow 0$ for $\lambda \rightarrow \infty$. Conclude that there is a unique value of λ , λ^* such that $f(\lambda^*) = 1$, and use this observation in proving the assertion. (*Note:* This can also be easily proved by Descartes' Rule of Signs.)

***(d)** Suppose that \mathbf{v}^* is the eigenvector corresponding to λ^* . Further suppose that $|\lambda^*|$ is strictly greater than $|\lambda|$ for any other eigenvalue λ of the Leslie matrix. Reason that successive generations will eventually produce an age distribution in which the ages are proportional to elements of \mathbf{v}^* . This is called a *stable age distribution*. (*Note:* Some confusion in the literature stems from the fact that Leslie matrices are formulated for systems in which a census of the population is taken *after* births occur. Compare with the plant-seed example, which was done in this way in problem 19 but in another way in Section 1.2. A good reference on this point is M. R. Cullen (1985), *Linear Models in Biology*, Halstead Press, New York.

REFERENCES

Several topics mentioned briefly in this chapter are suggested as excellent subjects for further independent study.

The Golden Mean and Fibonacci Numbers

Archibald, R. C. (1918). Golden Section, *American Mathematical Monthly*, 25, 232–238.
Bell, E. T. (1940). *The Development of Mathematics*. McGraw-Hill, New York.

- Coxeter, H. S. M. (1961). *Introduction to Geometry*. Wiley, New York.
- Gardner, M. (1961). *The Second Scientific American Book of Mathematical Puzzles and Diversions*. Simon & Schuster, New York.
- Huntley, H. E. (1970). *The Divine Proportion*. Dover, New York.

Patterns in Nature and Phyllotaxis

- Jean, R. V. (1984). *Mathematical Approach to Pattern and Form in Plant Growth*. Wiley, New York.
- Jean, R. V. (1986). A basic theorem on and a fundamental approach to pattern formation on plants. *Math. Biosci.*, 79, 127–154.
- Thompson, D'Arcy (1942). *On Growth and Form* (unabridged ed.). The University Press, Cambridge, U.K.

Linear Algebra

- Bradley, G. L. (1975). *A Primer of Linear Algebra*. Prentice-Hall, Englewood Cliffs, N. J.
- Johnson, L. W., and Riess, R. D. (1981). *Introduction to Linear Algebra*. Addison-Wesley, Reading, Mass.

Difference Equations

- Brand, L. (1966). *Differential and Difference Equations*. Wiley, New York.
- Grossman, S. I., and Turner, J. E. (1974). *Mathematics for the Biological Sciences*. Macmillan, New York, chap. 6.
- Sherbert, D. R. (1980). *Difference Equations with Applications*. UMAP Module 322, COMAP, Lexington, Mass. Published also in *UMAP Modules, Tools for Teaching*. Birkhauser, Boston (1982).
- Spiegel, M. R. (1971). *Calculus of Finite Differences and Difference Equations* (Schaum's Outline Series). McGraw-Hill, New York.

Miscellaneous

- Ellner, S. (1986). Germination Dimorphisms and Parent-Offspring Conflict in Seed Germination. *J. Theor. Biol.*, 123, 173–185.
- Glass, L., and Mackey, M. C. (1978). Pathological conditions resulting from instabilities in physiological control systems. *Ann. N. Y. Acad. Sci.*, 316, 214–235 (published 1979).
- Hoppensteadt, F. C. (1982). *Mathematical Methods of Population Biology*. Cambridge University Press, New York.
- Levin, S. A.; Cohen, D.; and Hastings, A. (1984). Dispersal strategies in patchy environments. *Theor. Pop. Biol.*, 26, 165–191.
- Mackey, M. C., and Glass, L. (1977). Oscillation and chaos in physiological control systems. *Science*, 197, 287–289.
- May, R. M. (1978). Dynamical Diseases. *Nature*, 272, 673–674.

- Prosser, J. I., and Trinci, A. P. J. (1979). A model for hyphal growth and branching. *J. Gen. Microbiol.*, 111, 153–164.
- Segel, L. A. (1981). A mathematical model relating to herbicide resistance. In W. E. Boyce, ed., *Case Studies in Mathematical Modeling*. Pitman Advanced Publishing, Boston.
- Whitham, T. G. (1980). The theory of habitat selection: examined and extended using *Pemphigus* aphids. *Am. Nat.*, 115, 449–466.

Demography (For Further Study)⁶

Historical accounts

- Burton, D. M. (1985). *The History of Mathematics: An Introduction*. Allyn and Bacon, Inc., Boston.
- Newman, J. R. (1956). *The World of Mathematics*, vol. 3. Simon & Schuster, New York, chaps. 1 and 2.
- Smith, D., and Keyfitz, N. (1977). *Mathematical Demography: selected papers*. Springer-Verlag, New York.

Leslie matrices and related models

- Fennel, R. E. (1976). Population growth: An age structured model. Chap. 2 in H. Marcus-Roberts and M. Thompson, eds., *Life Science Models*. Springer-Verlag, New York.
- Keller, E. (1978). *Population Projection*. UMAP Module 345, COMAP, Lexington, Mass.
- Leslie, P. H. (1945). On the use of matrices in certain population mathematics. *Biometrika*, 33; 183–212.
- Rorres, C., and Anton, H. (1977). *Applications of Linear Algebra*. Wiley, New York, chap. 13.
- Vandermeer, J. (1981). *Elementary Mathematical Ecology*. Wiley, New York.

Other references

- Charlesworth, B. (1980). *Evolution in Age-Structured Populations*. Cambridge University Press, New York.
- Impagliazzo, J. (1985). *Deterministic Aspects of Mathematical Demography*. Springer-Verlag, New York.

6. Compiled in part by Mike Halverson, Dale Irons, and Bill Shew.